

# UPM3

UPM3, UPM3 HYBRID, UPM3 AUTO, UPM3 AUTO L, UPM3 FLEX AS,  
UPM3 FLEX AC

1 x 230 V, 50 Hz



<b>1. Introduction</b>	<b>3</b>	REACH compliancy - Chemical Management -	
UPM3 - PWM variants	3	Grundfos Focus List	55
UPM3 - HYBRID variants	3	Declaration concerning GRUNDFOS' compliance with	
Applications	4	RoHS and WEEE directive	55
<b>2. Features and benefits</b>	<b>6</b>		
Features	6		
Benefits	6		
ErP, Ecodesign regulation in brief	6		
Identification	7		
<b>3. Performance range</b>	<b>9</b>		
<b>4. UPM external control mode and signals</b>	<b>11</b>		
Control principles	11		
<b>5. UPM3 HYBRID control modes, user interface and settings</b>	<b>14</b>		
User interface	15		
Navigation	16		
User interface control modes for UPM3 HYBRID variants	16		
<b>6. Technical description</b>	<b>24</b>		
Exploded view	24		
Sectional drawing	24		
Material specification	25		
Description of components	25		
<b>7. Installation</b>	<b>29</b>		
Mechanical installation	29		
Electrical installation	30		
<b>8. Startup</b>	<b>34</b>		
<b>9. Disposal</b>	<b>35</b>		
<b>10. Control box positions</b>	<b>36</b>		
<b>11. Dimensions (standard housings)</b>	<b>37</b>		
<b>12. Performance curves, technical data</b>	<b>38</b>		
Curve conditions	38		
<b>13. Data sheets</b>	<b>39</b>		
UPM3 15-75 130, 25-75 130, 25-75 180	39		
UPM3 15-70 130, 25-70 130, 25-70 180	40		
UPM3 15-60 130, 25-60 130, 25-60 180	41		
UPM3 15-50 130, 25-50 130, 25-50 180	42		
UPM3 15-40 130, 25-40 130, 25-40 180	43		
UPM3 FLEX AC 15-70 130, 25-70 130, 25-70 180	44		
UPM3 FLEX AS 15-70 130, 25-70 130, 25-70 180	45		
UPM3 AUTO L 15-70 130, 25-70 130, 25-70 180	46		
UPM3 AUTO L 15-50 130, 25-50 130, 25-50 180	47		
UPM3 AUTO 15-70 130, 25-70 130, 25-70 180	48		
UPM3 AUTO 15-50 130, 25-50 130, 25-50 180	49		
UPM3 HYBRID 15-70 130, 25-70 130, 25-70 180	50		
UPM3 HYBRID 15-50 130, 25-50 130, 25-50 180	51		
<b>14. Accessories</b>	<b>52</b>		
<b>15. Approvals and certificates</b>	<b>54</b>		
EC declaration of conformity	54		
VDE certificate	54		

# 1. Introduction

## UPM3 - PWM variants

UPM3	7.5 m	
UPM3	7 m	
UPM3	6 m	(only externally controlled PWM A/C profile)
UPM3	5 m	
UPM3	4 m	

## UPM3 - HYBRID variants

UPM3	HYBRID	7 m	(PWM A/C or PP/CP/CC/AA)
UPM3	HYBRID	5 m	
UPM3	FLEX AC	7 m	(only externally controlled PWM A/C profile)
UPM3	FLEX AS	7 m	(PWM A or CC)
UPM3	AUTO	7 m	(only internally controlled PP/CP/CC/AA)
UPM3	AUTO	5 m	
UPM3	AUTO L	7 m	(only internally controlled PP/CP/CC)
UPM3	AUTO L	5 m	

### Note:

PWM A/C: externally controlled via PWM profile A or profile C (see page 19)

PWM: pulse-width modulation

PP: Proportional Pressure

CP: Constant Pressure

CC: Constant Curve

AA: AUTO<sub>ADAPT</sub>

## Applications

In a modern heating, cooling and domestic hot water supply system there are different circuits in which UPM3 circulators in different versions can be placed. We need to differentiate between the heating (or cooling) production and its distribution. On the production side there are some applications using circulators in primary or internal circuits e.g. for geothermal or solar thermal brine circuits as today's UPM GEO or SOLAR PM.

The distribution side is often separated into two circuits - a primary and a secondary circuit - in order to keep the flow and/or temperature independent from each other. You can use a heat exchanger, a hydraulic separator or a buffer tank for this separation. The primary circulator is mostly integrated into the heating appliance and it is controlled by it via a digital signal (e.g. PWM) to ensure the optimum operation of for instance the boiler. In a combi-boiler, the circulator supplies both the heating system and the hot water supply.

The secondary circulator is often a self-controlled, stand-alone circulator which is e.g. mounted in a heating kit, and reacts on the changing flow demand of the heat consumers like radiators or underfloor heating circuits. If an automatic bypass valve is installed to ensure a minimum flow, you must adjust the differential pressure control of the circulator in a way to ensure the function of the circulator. For example, select a constant pressure curve that is higher than the differential pressure of the valve.

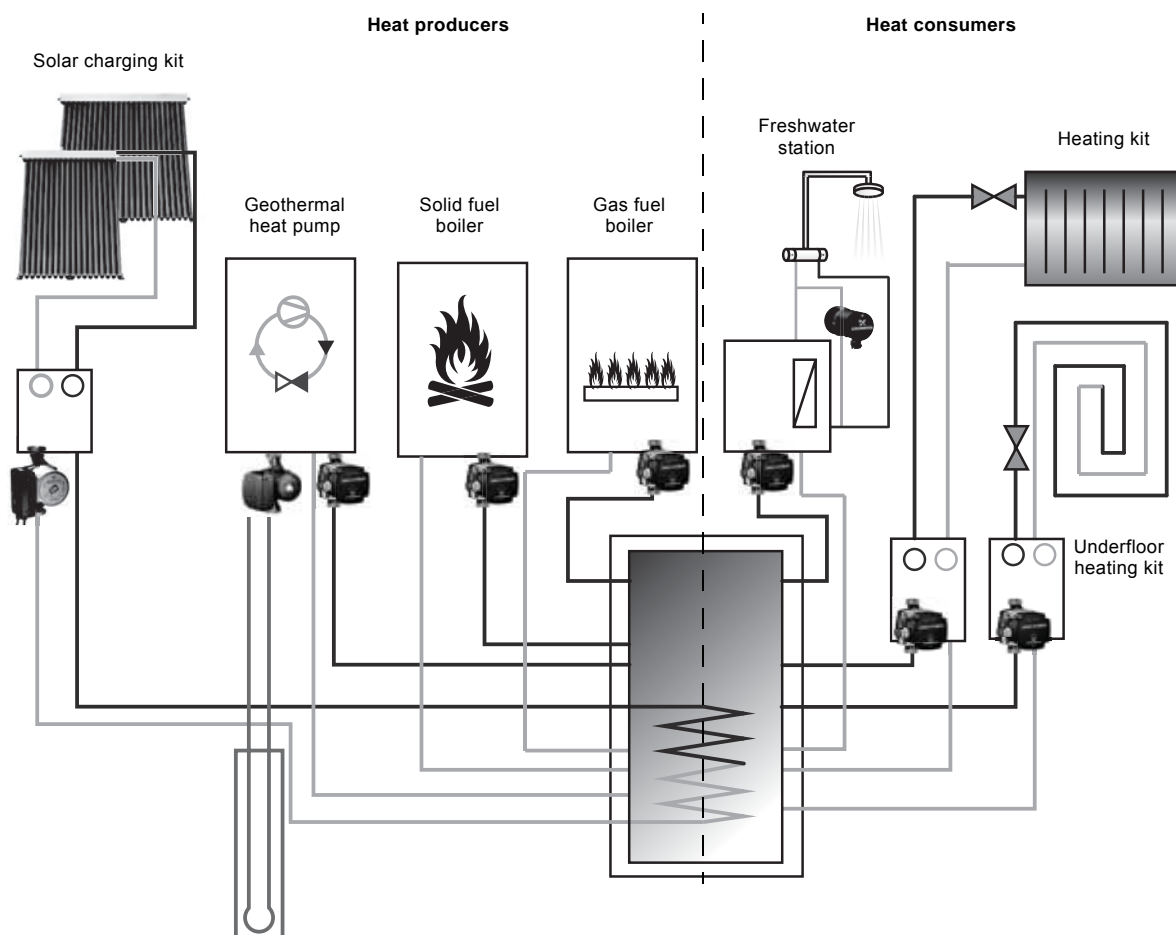

Fig. 1 Complete domestic heating system combined with renewable energy sources

TM06 0522 0414

In indirect heated DHW systems, the circulator might be placed on both sides of the heat exchanger. In a DHW cylinder, potable water is stored and usually heated indirectly by primary heating water from the boiler either by an external plate heat exchanger or by an internal indirect coil. Especially in renewable energy sourced systems, the primary heating water gets stored and instant hot water is created by fresh water stations. Hot water recirculation circulators circulate the potable water on the secondary side from the taps back to the water heater to ensure comfort and to avoid legionella.

### UPM3 - PWM variants

This circulator range is designed for integration in boilers and other heating appliances with remote control of the speed, corresponding to low-voltage PWM signal input.

### UPM3 - HYBRID variants

This circulator range with user interface is designed for several purposes:

- As an internal controlled variant, it can be used in heating applications as either a stand-alone or replacement circulator e.g. in heating kits.
- As a remote controlled variant, it can be integrated in boilers and other heating appliances in which the speed is changed, corresponding to low-voltage PWM signal input.
- As a combination of the above-mentioned variants.

The internal controlled variants are suitable for the following systems:

- systems with constant or less variable flows as e.g. one-pipe heating systems
- systems with variable flows as e.g. two-pipe heating systems with thermostatic valves for radiators or underfloor heating.

### Examples of systems

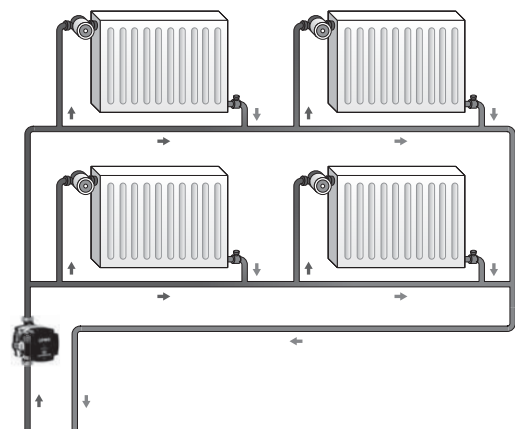

Fig. 2 One-pipe heating system

TM06 0528 0414

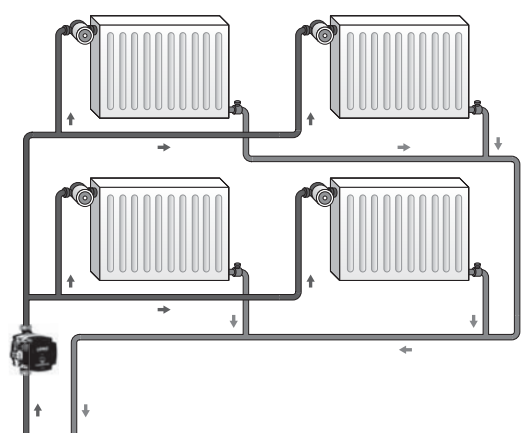

Fig. 3 Two-pipe heating system

TM06 0526 0414

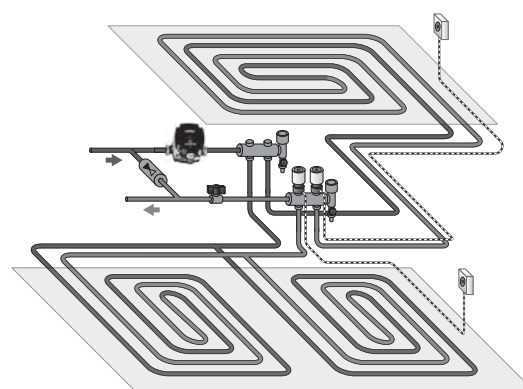

Fig. 4 Underfloor heating system

TM06 0526 0414

## 2. Features and benefits

### Features

- Speed-controlled, high-efficiency circulator fitted with electronically commutated motor (ECM) with permanent-magnet rotor and frequency converter.
- Either externally controlled by digital pulse-width modulation (PWM) low-voltage signal or internally controlled in constant pressure, proportional pressure or constant speed mode defined by the means of a smart user interface or factory pre-setting.
- Third generation of the first boiler-integrated, variable-speed ECM circulators which combines both validated and newly developed components and concepts.
- Highly reliable as more than 1,000,000 UPM units have been installed with success since 2006.
- Fit into existing boiler ranges, small as UP15 standard circulators.
- Cost-optimised and reliably available due to new established mass production facilities.
- Energy-optimised due to improved hydraulic and motor efficiency.

### Benefits

- Use up to 87 % less electrical power than conventional constant-speed circulators.
- Use up to 68 % less electrical power than conventional speed-controlled circulators.
- Use up to 25 % less electrical power than the first generation of ECM pumps.

### Unique Selling Points of UPM3 and UPM3 HYBRID variants

- UPM3 is the first Grundfos high efficiency circulator with terminal box in front and access to a mechanical de-blocking device.
- UPM3 is the first Grundfos high efficiency circulator for high ambient and media temperature of up to 70 °C/110 °C
- UPM3 is the first Grundfos high efficiency circulator with relay for active inrush current limitation to 4 Amps
- UPM3 is the first Grundfos high efficiency, PWM controlled circulator with an EEI below benchmark level of  $EEI \leq 0.20$ . Therefore, it fulfils the ecodesign requirements for 2015.
- UPM3 is the first Grundfos OEM circulator with TE Superseal connectors for power and signal supply.
- UPM FLEX AC is the first Grundfos PWM controlled circulator with flexible setting of maximum curve of the speed control range and its profile A or C.
- UPM3 AUTO is the first Grundfos self-controlled circulator with AUTOADAPT constant pressure mode, which can be used in underfloor heating systems.
- UPM3 HYBRID is the first hybrid version of externally and internally controlled, high efficiency Grundfos circulators.

### ErP, Ecodesign regulation in brief

The EU has addressed the climate challenge in a EuP/ErP directive: Since 2013 all stand-alone circulators must fulfil Ecodesign requirements, defined in regulation 641/2009/EC on glandless circulators, which was amended by 622/2012/EC. In August 2015, the second step of this regulation will take effect and apply to integrated circulators in products as well. The regulation will set radically new standards for energy efficiency in circulators integrated in boiler, solar and heat pump systems.

#### The essentials

- Glandless circulators integrated in products must have an energy efficiency index (EEI) of not more than 0.23. The benchmark level is 0.20.
- Stand-alone circulators will be measured according to EN 16297-2.
- Integrated circulators will be measured according to EN 16297-3. due to the various integrated functions in the many customized hydraulic solutions on the market.
- All circulators integrated in products which generate and/or transfer heat, and all types of media, are included. This means that not only heating systems, but also solar thermal and heat circulator systems, will be affected by the Ecodesign regulation.
- Spare circulators for integrated circulators sold before August 2015 are allowed until 2020.
- Conformity with EU regulations will be governed through mandatory CE marking.

#### UPM3 circulators are "ErP-ready"

The UPM3 and UPM3 HYBRID variants already meet the new ecodesign requirements from 2015 measured by EN 16297-2 and EN 16297-3:2012.

#### Pumped liquids

- Thin, clean, non-aggressive and non-explosive liquids, not containing solid particles, fibres or mineral oil.
- In heating systems, the water should meet the requirements of accepted standards on water quality in heating systems, for example the German standard VDI 2035-1.
- In domestic hot-water systems, the circulator should be used only for water with a degree of hardness lower than approximately 17 °dH.
- Mixtures of water with antifreeze media such as glycol with a kinematic viscosity lower than 10 m<sup>2</sup>/s.

**Note:** The circulator must not be used for circulation of flammable liquids such as diesel oil and petrol.

## Identification

### Type key

Example	UPM3 HYBRID	15 - 70	130	AC	A	EU	X	9
UPM3 externally controlled (PWM) version								
UPM3 FLEX AC with user interface								
UPM3 FLEX AS with user interface								
UPM3 AUTO L with user interface								
UPM3 AUTO with user interface								
UPM3 HYBRID with user interface								
Nominal diameter (DN) of suction and discharge ports [mm]								
Maximum head [dm]								
Material: [ ]: Cast-iron pump housing N: Stainless steel pump housing CESAO, CACAO, CIL3: Composite PH. Pump without housing								
Port-to-port length [mm]								
External signal and profile: PWM [A+C]								
Min. speed: Low [A] High [J]								
Voltage range: 230 VAC [EU]								
Control signal connector: Mini Superseal [X] FCI [Y]								
Connector position: 9h [9]								

## Nameplate

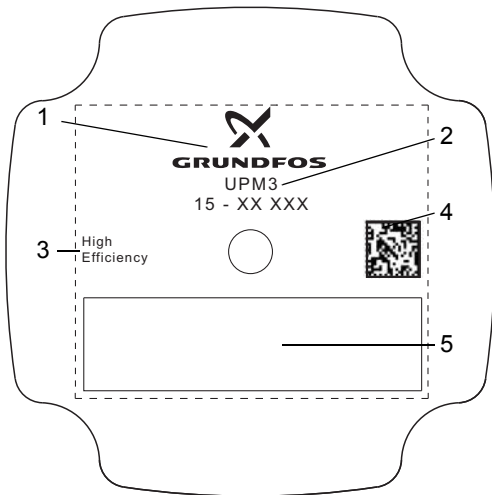

Fig. 1 Nameplate

Pos.	Description
1	Grundfos logo
2	Type designation
3	High efficiency indicating ECM technology
4	Data matrix
5	Customer area indicating the customer's specific requirements

TM06 0525 0614

## Terminal box side

①	②	③	④
	$I_{1/1}$ (A)	$P_1$ (W)	MPa
Min.	X.XX	XX	
Max.	X.XX	XXX	X.X
⑤	⑥		⑦
CE	VDE		GFNJX
⑧	EEI ≤ 0.XX - Part X	$P_{L,avg} < XXW$	⑨
⑩	XXXV~XX/XXHz	IPXXX TFXXX	⑭
⑪	⑫	⑬	⑮
		Min. XX°C	
⑯	PN:XXXXXXXX	PC:XXXXXXXX	⑰
⑱	SN:XXXXXXXX		
⑲	Made in XXXXXX		

Fig. 2 Terminal box side

Pos.	Terminal box side
1	Speed
2	Rated current, $I_{1/1}$ [A] at maximum and minimum
3	Input power $P_1$ [W] at maximum and minimum
4	Maximum system pressure [MPa]
5	CE mark
6	Approvals
7	VDE code
8	Energy index with indication of measurement standard
9	Average power input $P_{L,avg}$ (Ecodesign regulation)
10	Voltage [V]
11	Power supply voltage AC
12	Frequency [Hz]
13	Enclosure class
14	Temperature class
15	Minimum medium temperature (only cold water pumps)
16	Product number PN
17	Production code PC (YYWWCustomerID)
18	Serial number SN
19	Place of production

TM06 0534 0614



### 3. Performance range

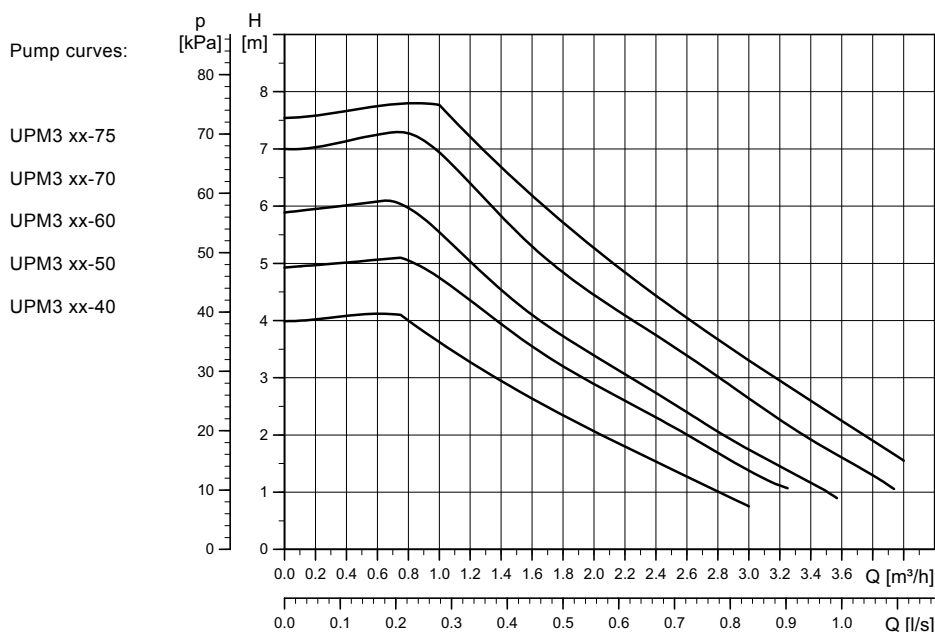

TM06 0585 0514

Fig. 3 Performance range UPM3, cast iron pump housing

Pump type	Port-to-port length [mm]	Connection pipe thread	Control signal		Voltage + 10/- 15 % 50 Hz
			Internally controlled PP/CP/CC	Digital low voltage PWM bidirectional	
UPM3 15-75 130	130	R 1/2 / G 1	-	•	1 x 230 V
UPM3 25-75 130	130	R 1 / G 1 1/2	-	•	1 x 230 V
UPM3 25-75 180	180	R 1 / G 1 1/2	-	•	1 x 230 V
UPM3 15-70 130	130	R 1/2 / G 1	-	•	1 x 230 V
UPM3 25-70 130	130	R 1 / G 1 1/2	-	•	1 x 230 V
UPM3 25-70 180	180	R 1 / G 1 1/2	-	•	1 x 230 V
UPM3 15-60 130	130	R 1/2 / G 1	-	•	1 x 230 V
UPM3 25-60 130	130	R 1 / G 1 1/2	-	•	1 x 230 V
UPM3 25-60 180	180	R 1 / G 1 1/2	-	•	1 x 230 V
UPM3 15-50 130	130	R 1/2 / G 1	-	•	1 x 230 V
UPM3 25-50 130	130	R 1 / G 1 1/2	-	•	1 x 230 V
UPM3 25-50 180	180	R 1 / G 1 1/2	-	•	1 x 230 V
UPM3 15-40 130	130	R 1/2 / G 1	-	•	1 x 230 V
UPM3 25-40 130	130	R 1 / G 1 1/2	-	•	1 x 230 V
UPM3 25-40 180	180	R 1 / G 1 1/2	-	•	1 x 230 V
UPM3 HYBRID 15-70 130	130	R 1/2 / G 1	•	•	1 x 230 V
UPM3 HYBRID 25-70 130	130	R 1 / G 1 1/2	•	•	1 x 230 V
UPM3 HYBRID 25-70 180	180	R 1 / G 1 1/2	•	•	1 x 230 V
UPM3 HYBRID 15-50 130	130	R 1 / G 1 1/2	•	•	1 x 230 V
UPM3 HYBRID 25-50 180	180	R 1 / G 1 1/2	•	•	1 x 230 V
UPM3 FLEX AC 15-70 130	130	R 1/2 / G 1	-	•	1 x 230 V
UPM3 FLEX AC 25-70 130	130	R 1 / G 1 1/2	-	•	1 x 230 V
UPM3 FLEX AC 25-70 180	180	R 1 / G 1 1/2	-	•	1 x 230 V
UPM3 FLEX AS 15-70 130	130	R 1/2 / G 1	•	•	1 x 230 V
UPM3 FLEX AS 25-70 130	130	R 1 / G 1 1/2	•	•	1 x 230 V
UPM3 FLEX AS 25-70 180	180	R 1 / G 1 1/2	•	•	1 x 230 V
UPM3 AUTO L 15-70 130	130	R 1/2 / G 1	•	-	1 x 230 V
UPM3 AUTO L 25-70 130	130	R 1 / G 1 1/2	•	-	1 x 230 V
UPM3 AUTO L 25-70 180	180	R 1 / G 1 1/2	•	-	1 x 230 V
UPM3 AUTO L 15-50 130	130	R 1/2 / G 1	•	-	1 x 230 V
UPM3 AUTO L 25-50 130	130	R 1 / G 1 1/2	•	-	1 x 230 V
UPM3 AUTO L 25-50 180	180	R 1 / G 1 1/2	•	-	1 x 230 V

Pump type	Port-to-port length [mm]	Connection pipe thread	Control signal		Voltage + 10/- 15 % 50 Hz
			Internally controlled PP/CP/CC	Digital low voltage PWM bidirectional	
UPM3 AUTO 15-70 130	130	R 1/2 / G 1	•	-	1 x 230 V
UPM3 AUTO 25-70 130	130	R 1 / G 1 1/2	•	-	1 x 230 V
UPM3 AUTO 25-70 180	180	R 1 / G 1 1/2	•	-	1 x 230 V
UPM3 AUTO 15-50 130	130	R 1/2 / G 1	•	-	1 x 230 V
UPM3 AUTO 25-50 130	130	R 1 / G 1 1/2	•	-	1 x 230 V
UPM3 AUTO 25-50 180	180	R 1 / G 1 1/2	•	-	1 x 230 V

Other versions or housings with different dimensions, materials, design or functionality are available on request. Please contact your Grundfos HVAC OEM KAM.

## 4. UPM external control mode and signals

### Control principles

The UPM3 and UPM3 FLEX circulators are controlled via a digital low-voltage pulse-width modulation (PWM) signal which means that the speed of rotation depends on the input signal. UPM3 HYBRID circulators are controlled either internally or externally can be set to either internal or externally controlled. The speed changes as a function of the input profile. These communication signals are standardized in the VDMA Einheitsblatt 24244 "Wet runner circulating pumps - Specification of PWM control signals".

### Control signals

#### Digital low-voltage PWM signal

The square-wave PWM signal is designed for a 100 to 4,000 Hz frequency range. The PWM signal is used to select the speed (speed command) and as feedback signal. The PWM frequency on the feedback signal is fixed at 75 Hz in the circulator.

#### Duty cycle

$$d \% = 100 \times t/T$$

Example	Rating
T = 2 ms (500 Hz)	$U_{iH} = 4-24 \text{ V}$
t = 0.6 ms	$U_{iL} \leq 1 \text{ V}$
d % = $100 \times 0.6 / 2 = 30 \%$	$I_{iH} \leq 10 \text{ mA}$ (depending on $U_{iH}$ )

#### Example

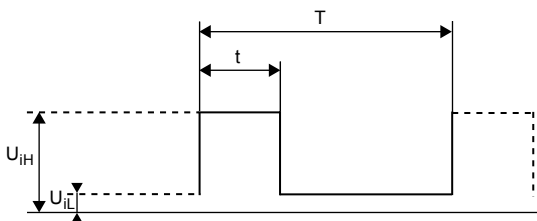

TM04 9911 0211

Fig. 4 PWM signal

Abbreviation	Description
T	Period of time [sec.]
d	Duty cycle [t/T]
$U_{iH}$	High-level input voltage
$U_{iL}$	Low-level input voltage
$I_{iH}$	High-level input current

### Interface

The UPM3 PWM interface consists of an electronic part connecting the external control signal to the circulator. The interface translates the external signal into a signal type that the microprocessor can understand.

In addition, the interface ensures that the user cannot get into contact with dangerous voltage if touching the signal wires when power is connected to the circulator.

**Note:** "Signal ref." is a signal reference with no connection to protective earth.

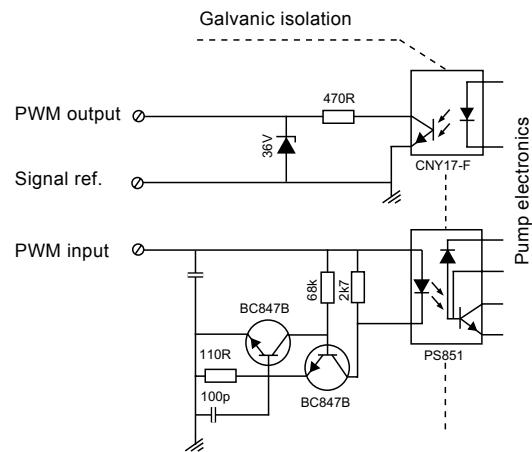

TM06 0787 0914

Fig. 5 Schematic drawing, interface

### PWM input signal profile A (heating)

At high PWM signal percentages (duty cycles), a hysteresis prevents the circulator from starting and stopping if the input signal fluctuates around the shifting point. At low PWM signal percentages, the circulator speed is high for safety reasons. In case of a cable breakage in a gas boiler system, the circulators will continue to run at maximum speed to transfer heat from the primary heat exchanger. This is also suitable for heat circulators to ensure that the circulators transfer heat in case of a cable breakage.

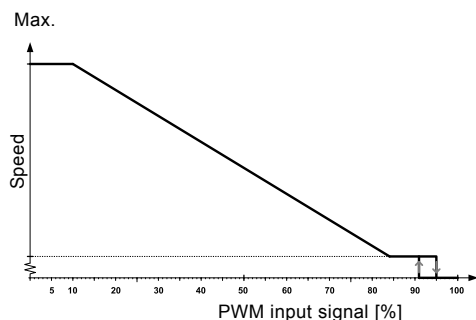

TM04 9985 0311

Fig. 6 PWM input profile A (heating)

PWM input signal [%]	Pump status
$\leq 10$	Maximum speed: max.
$> 10 / \leq 84$	Variable speed: min. to max.
$> 84 / \leq 91$	Minimum speed: IN
$> 91/95$	Hysteresis area: on/off
$> 95 / \leq 100$	Standby mode: off

### PWM input signal profile C (solar)

At low PWM signal percentages (duty cycles), a hysteresis prevents the circulator from starting and stopping if the input signal fluctuates around the shifting point. Without PWM signal percentages, the circulator will stop for safety reasons. If a signal is missing, for example due to a cable breakage, the circulator will stop to avoid overheating of the solar thermal system.

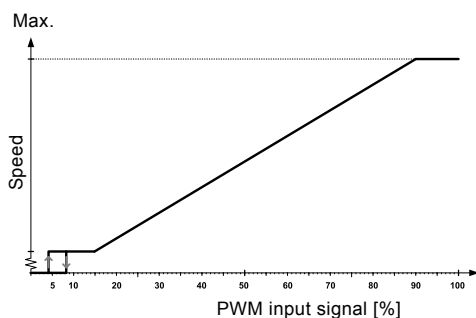

TM05 1575 3211

Fig. 7 PWM input profile C (solar)

PWM input signal [%]	Pump status
$\leq 5$	Standby mode: off
$> 5 / \leq 8$	Hysteresis area: on/off
$> 8 / \leq 15$	Minimum speed: IN
$> 15 / \leq 90$	Variable speed: min. to max.
$> 90 / \leq 100$	Maximum speed: max

### PWM feedback signal - power consumption (standard)

The PWM feedback signal offers pump information like in BUS systems:

- current power consumption (accuracy  $\pm 2\%$  of PWM signal)
- warning
- alarm
- operation status.

### Alarms

Alarm output signals are available because some PWM output signals are dedicated to alarm information. If a supply voltage is measured below the specified supply voltage range, the output signal is set to 75%. If the rotor is locked due to deposits in the hydraulics, the output signal is set to 90% because this alarm has a higher priority.

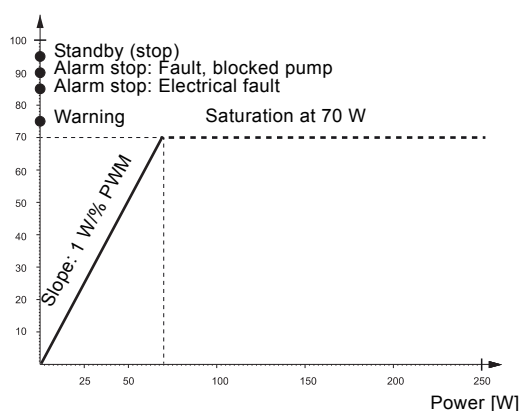

TM05 0006 0411

Fig. 8 PWM feedback signal - power consumption

PWM output signal [%]	QT [s]	Pump info	DT [s]	Priority
95	0	Standby (STOP) by PWM signal	0	1
90	30	Alarm, stop, blocked error	12	2
85	0-30	Alarm, stop, electrical error	1-12	3
75	0	WARNING	0	5
0-10		0-70 W (slope 1 W/% PWM)		6

Output frequency: 75 Hz  $\pm$  5 %

Note: QT =qualification time, DT =disqualification time

**PWM feedback signal - flow estimation (on demand)**

On demand there will be an option that the PWM feedback signal can also be used to indicate the flow of the circulator on defined pump housings. The accuracy of the feedback signal is depending on the operation point and media temperature, but it gives a good indication on the actual flow.

Example: In this case the PWM output range between 0-70 % shows the flow between 0 and 2.1 m<sup>3</sup>/h with a slope of 0.03 m<sup>3</sup>/h / % PWM.

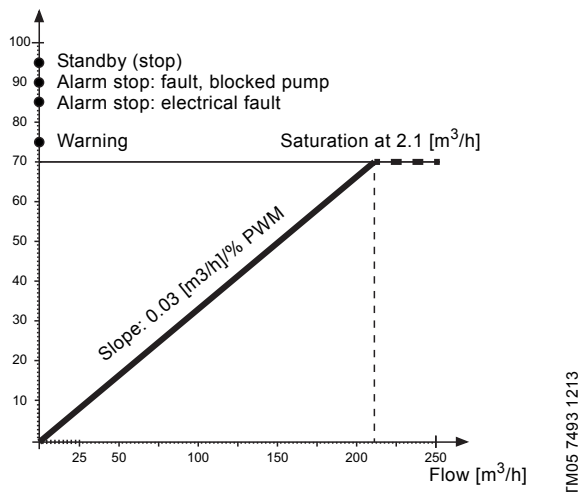

Fig. 9 PWM feedback signal - flow estimation

**Data**

Maximum rating	Symbol	Value
PWM frequency input with high-speed optocoupler	f	100-4000 Hz
Guaranteed standby power consumption		< 1 W
Rated input voltage - high level	U <sub>IH</sub>	4-24 V
Rated input voltage - low level	U <sub>IL</sub>	< 1 V
High-level input current	I <sub>IH</sub>	< 10 mA
Input duty cycle	PWM	0-100 %
PWM frequency output, open collector	f	75 Hz ± 5 %
Accuracy of output signal regarding power consumption	-	± 2 % (of PWM signal)
Output duty cycle	PWM	0-100 %
Collector emitter breakdown voltage on output transistor	U <sub>c</sub>	< 70 V
Collector current on output transistor	I <sub>c</sub>	< 50 mA
Maximum power dissipation on output resistor	P <sub>R</sub>	125 mW
Zener diode working voltage	U <sub>z</sub>	36 V
Maximum power dissipation in Zener diode	P <sub>z</sub>	300 mW

## 5. UPM3 HYBRID control modes, user interface and settings

### HYBRID control modes and curves

There are up to five different control modes and up to four curves and they are all available in UPM3 HYBRID as 5 m or 7 m version.

Externally controlled		Internally controlled		
PWM Profile A [m]	PWM Profile C [m]	Proportional Pressure	Constant Pressure	Constant Curve [m]
4/2	4/2	Curve 1	Curve 1	4/2
5/3	5/3	Curve 2	Curve 2	5/3
6/4	6/4	Curve 3	Curve 3	6/4
7/5	7/5	AUTO <sub>ADAPT</sub>	AUTO <sub>ADAPT</sub>	7/5

### HYBRID variants

The setting options can be delivered as pre-configured settings.

Variant	Application	Functionality	Externally controlled		Internally controlled		Number of settings	Factory-set
<b>HYBRID</b>	Any HVAC system	Full access to all available modes and curves	PWM A	4	PP	3+ AA	20	PP3
			PWM C	4	CP	3+ AA		
					CC	4		
<b>AUTO</b>	Heating kits DHW System	Full access to all self-controlled modes and curves			PP	3+ AA	12	PP3
					CP	3+ AA		
					CC	4		
<b>AUTO L</b>	Heating kits DHW System	Full access to all self-controlled modes and curves, except AUTO <sub>ADAPT</sub>			PP	3	10	PP3
					CP	3		
					CC	4		
<b>FLEX AC</b>	Heating and/or solar Thermal systems	Full access to externally controlled profiles and heads	PWM A	4			8	A7m
			PWM C	4				
<b>FLEX AS</b>	Heating appliances	Runs with or without PWM signal	PWM A	4	CC	4	4	A7m

## User interface

The user interface is designed with a single push button, one red/green LED and four yellow LEDs.

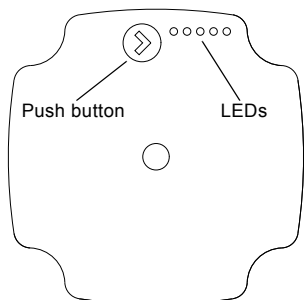

TM06 0535 0414

Fig. 10 User interface with one push button and five LEDs

The user interface shows:

- performance view (during operation)
  - operation status
  - alarm status
- settings view (after pressing the button).

During operation, the display shows the performance view. If you press the button, the user interface switches the view or runs in the setting selection mode.

### Performance view

The performance view shows either the operation status or the alarm status.

#### Operation status

When the circulator is running, LED 1 is green. The four yellow LEDs indicate the current power consumption (P1) as shown in the table below. See fig. 11. When the operation mode is active, all active LEDs are constantly on in order to differentiate this mode from the select setting mode. If the circulator is stopped by an external signal, LED 1 flashes green.

Display	Indication	Performance in % of P1 MAX
One green LED (flashing)	Standby (only externally controlled)	0
One green LED + one yellow LED	Low performance	0-25
One green LED + two yellow LED	Medium low performance	25-50
One green LED + three yellow LED	Medium high performance	50-75
One green LED + four yellow LED	High performance	75-100

### Operation area

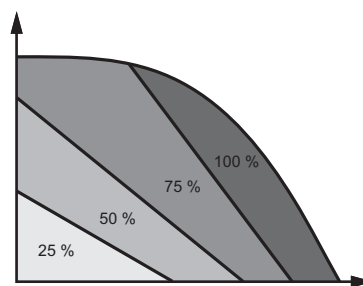

TM06 0550 0414

Fig. 11 Operation area according to performance load

### Alarm status

If the circulator has detected one or more alarms, the bi-colored LED 1 switches from green to red. When an alarm is active, the LEDs indicate the alarm type as defined in the table below. If multiple alarms are active at the same time, the LEDs only show the error with the highest priority. The priority is defined by the sequence of the table.

When there is no active alarm anymore, the user interface switches back to operation mode.

Display	Indication	Pump operation	Counter action
One red LED + one yellow LED (LED 5)	Rotor is blocked.	Trying to start again every 1.33 seconds.	Wait or deblock the shaft.
One red LED + one yellow LED (LED 4)	Supply voltage too low.	Only warning, pump runs.	Control the supply voltage.
One red LED + one yellow LED (LED 3)	Electrical error.	Pump is stopped because of low supply voltage or serious failure.	Control the supply voltage / Exchange the pump.

### Settings view

You can switch from the performance view to the settings view by pressing the push button. The LEDs indicate the actual setting. The settings view shows which mode controls the circulator. No settings can be made at this stage. After 2 seconds, the display switches back to performance view.

If LED 1 is green, it indicates operation or internal control. If LED 1 is red, it indicates alarm or external control. LED 2 and 3 indicate the different control modes and LED 4 and 5 indicate the different curves.

	LED 1	LED 2	LED 3	LED 4	LED 5
Proportional pressure	green	•			
Constant pressure	green		•		
Constant curve	green	•	•		
PWM A profile	red	•			
PWM B profile	red		•		
Curve 1					
Curve 2				•	
Curve 3				•	•
Curve 4/AUTO <sub>ADAPT</sub>					•

Note: • = The LED is yellow.

## Navigation

### Key lock function

The purpose of the key lock function is to avoid accidental change of settings and misuse.

When the key lock function is enabled, all long key presses will be ignored. This prevents the user from entering the "select setting mode" area and allows the user to see the "show setting mode" area.

If you press the key lock for more than 10 seconds, you can toggle between enabling/disabling the key lock function. When doing so, all LEDs, except for the red LED, will flash for a second indicating that lock is toggled.



TM06 0552 0914

### Factory presetting

The circulator starts at the factory preset.

- For standard UPM3 HYBRID, UPM3 AUTO, UPM3 AUTO L this is proportional pressure, curve 3
- For UPM3 FLEX AC and UPM3 FLEX AS this is PWM profile A, curve 4.

In the "select setting" mode the circulator starts at this control mode. The preset mode is marked with this symbol \* in the tables below.

### Setting selection

You can choose between the performance view and settings view.

If you press the button for 2 to 10 seconds, the user interface switches to "setting selection" if the user interface is unlocked. You can change the settings as they appear. The settings appear in a particular order in a closed loop. When you release the button, the user interface switches back to the performance view and the last setting is stored.

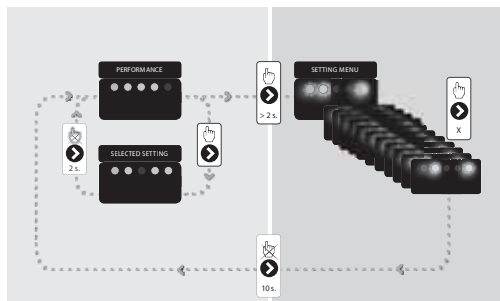

TM06 0856 1014

Fig. 12 Setting selection

## User interface control modes for UPM3 HYBRID variants

You can manage all UPM3 HYBRID variants with a single push button and a LED interface.

You can select the following operation modes with the push button.

The user interface shows the flashing LEDs in the combination which is described in the tables below.

### UPM3 FLEX AS

This circulator is for either external PWM profile A signal control or speed selection.

You can define the maximum curve of the pump operation range. With PWM signal, the circulator runs at the corresponding speed. Without PWM signal, the circulator runs at maximum speed.

#### PWM profile A (heating)

UPM3 xx-70 [m]	LED1 red	LED2 yellow	LED3 yellow	LED4 yellow	LED5 yellow
4	•	•			
5	•	•		•	
6	•	•		•	•
7*	•	•			•

\* The circulator is factory-set to start in this control mode.

### UPM3 FLEX AC

This circulator is for external PWM signal control with profile A or C.

It gives the opportunity to define the maximum curve of the pump operation and its profile.

#### PWM profile A (heating)

UPM3 xx-70 [m]	LED1 red	LED2 yellow	LED3 yellow	LED4 yellow	LED5 yellow
4	•	•			
5	•	•		•	
6	•	•		•	•
7*	•	•			•

\* The circulator is factory-set to start in this control mode.

#### PWM profile C (solar)

UPM3 xx-70 [m]	LED1 red	LED2 yellow	LED3 yellow	LED4 yellow	LED5 yellow
4	•		•		
5	•		•	•	
6	•		•	•	•
7	•		•		•



### UPM3 AUTO L

This circulator is for internal control with three control modes without AUTO<sub>ADAPT</sub>

#### Proportional pressure mode

UPM3 xx-50	UPM3 xx-70	LED1 Green	LED2 yellow	LED3 yellow	LED4 yellow	LED5 yellow
PP1	PP1	•	•			
PP2	PP2	•	•		•	
PP3*	PP3*	•	•		•	•

PP: proportional pressure curve: 1, 2, or 3.  
\* The circulator is factory-set to start in this control mode.

#### Constant pressure mode

UPM3 xx-50	UPM3 xx-70	LED1 Green	LED2 yellow	LED3 yellow	LED4 yellow	LED5 yellow
CP1	CP1	•		•		
CP2	CP2	•		•	•	
CP3	CP3	•		•	•	•

CP: constant pressure curve 1, 2, or 3.

#### Constant curve mode

UPM3 xx-50	UPM3 xx-70	LED1 Green	LED2 yellow	LED3 yellow	LED4 yellow	LED5 yellow
CC1	CC1	•	•	•		
CC2	CC2	•	•	•	•	
CC3	CC3	•	•	•	•	•

CC: constant curve 1, 2, or 3.

### UPM3 AUTO

This circulator is for internal control with three control modes plus AUTO<sub>ADAPT</sub>

#### Proportional pressure mode

UPM3 xx-50	UPM3 xx-70	LED1 Green	LED2 yellow	LED3 yellow	LED4 yellow	LED5 yellow
PP1	PP1	•	•			
PP2	PP2	•	•		•	
PP3*	PP3*	•	•		•	•
AUTO <sub>ADAPT</sub>	AUTO <sub>ADAPT</sub>	•	•			•

PP: proportional pressure curve 1, 2, or 3.  
\* The circulator is factory-set to start in this control mode.

#### Constant pressure mode

UPM3 xx-50	UPM3 xx-70	LED1 Green	LED2 yellow	LED3 yellow	LED4 yellow	LED5 yellow
CP1	CP1	•		•		
CP2	CP2	•		•	•	
CP3	CP3	•		•	•	•
AUTO <sub>ADAPT</sub>	AUTO <sub>ADAPT</sub>	•		•		•

CP: constant pressure curve: 1, 2, or 3.

#### Constant curve mode

UPM3 xx-50 [m]	UPM3 xx-70 [m]	LED1 Green	LED2 yellow	LED3 yellow	LED4 yellow	LED5 yellow
2	4	•	•	•		
3	5	•	•	•	•	
4	6	•	•	•	•	•
5	7	•	•	•	•	•

### UPM3 HYBRID

This circulator gives the opportunity of external PWM signal control with profile A or C or internal control with three control modes plus AUTO<sub>ADAPT</sub>

#### Proportional pressure mode

UPM3 xx-50	UPM3 xx-70	LED1 Green	LED2 yellow	LED3 yellow	LED4 yellow	LED5 yellow
PP1	PP1	•	•			
PP2	PP2	•	•		•	
PP3*	PP3*	•	•		•	•
AUTO <sub>ADAPT</sub>	AUTO <sub>ADAPT</sub>	•	•			•

PP: proportional pressure curve 1, 2, or 3.  
\* The circulator is factory-set to start in this control mode.

#### Constant pressure mode

UPM3 xx-50	UPM3 xx-70	LED1 Green	LED2 yellow	LED3 yellow	LED4 yellow	LED5 yellow
CP1	CP1	•		•		
CP2	CP2	•		•	•	
CP3	CP3	•		•	•	•
AUTO <sub>ADAPT</sub>	AUTO <sub>ADAPT</sub>	•		•		•

CP: constant pressure curve: 1, 2, or 3.

#### Constant curve mode

UPM3 xx-50 [m]	UPM3 xx-70 [m]	LED1 Green	LED2 yellow	LED3 yellow	LED4 yellow	LED5 yellow
2	4	•	•	•		
3	5	•	•	•	•	
4	6	•	•	•	•	•
5	7	•	•	•	•	•

#### PWM profile A (heating)

UPM3 xx-50 [m]	UPM3 xx-70 [m]	LED1 red	LED2 yellow	LED3 yellow	LED4 yellow	LED5 yellow
2	4	•	•			
3	5	•	•		•	
4	6	•	•		•	•
5	7	•	•		•	•

#### PWM profile C (solar)

UPM3 xx-50 [m]	UPM3 xx-70 [m]	LED1 red	LED2 yellow	LED3 yellow	LED4 yellow	LED5 yellow
2	4	•		•		
3	5	•		•	•	
4	6	•		•	•	•
5	7	•		•	•	•

## toggling the settings of UPM3

When you switch on the circulator, it runs with the factory pre-setting or the last setting. The display shows the current operation status.

1. Press the button to switch to the setting view. The LEDs show the current setting for 2 seconds.
2. Release the button for more than 2 seconds. The user interface shows the current performance in "operation status".
3. Press the button for more than 2 seconds and the circulator switches to "setting selection". The LEDs flash and show the current setting mode. Please note that if the key lock is disabled, the circulator will not switch to "setting selection". In this case, unlock the key lock by pressing the button for more 10 seconds.
4. During a period of 10 seconds, press shortly on the button and the circulator switches to the next setting.
5. To select between the settings, instantly press the button until you find the setting you want. If you pass a setting, you need to continue until the setting appears again as it is not possible to go back in the settings menu.
6. Release the button for more than 10 seconds and the user interface switches back to the performance view and the last setting is stored.
7. Press the button and the display switches to the setting view and the LEDs show the current setting for 2 seconds.
8. Release the button for more than 2 seconds and the user interface switches back to the performance view.

## Settings navigation

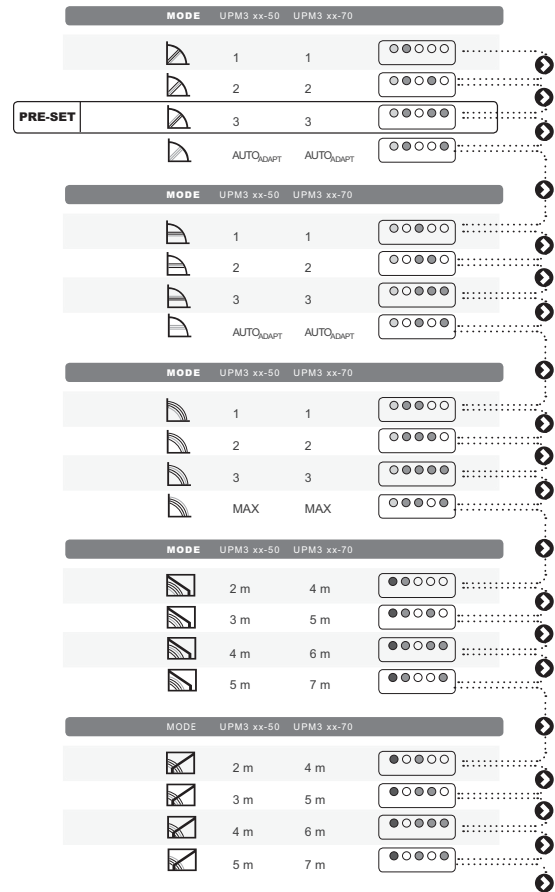

Fig. 13 Settings navigation

## Control modes with pump curves

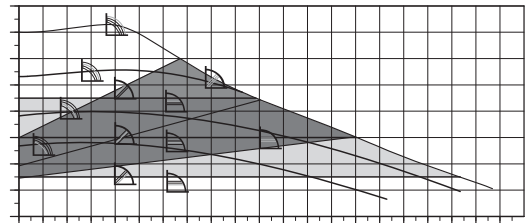

Fig. 14 UPM3 AUTO/HYBRID control modes with pump curves

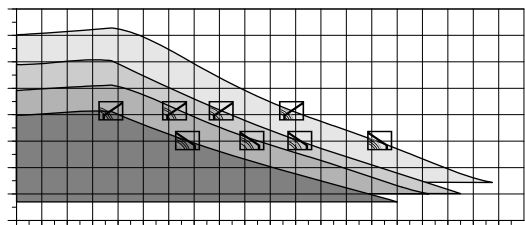

Fig. 15 UPM3 FLEX/HYBRID control modes with pump curves

## Control mode explanation

### Proportional pressure

The head (pressure) is reduced at falling heat demand and increased at rising heat demand.

The duty point of the circulator will move up or down on the selected proportional-pressure curve, depending on the heat demand in the system.



TM06 0704 0814

- PP1: lowest proportional pressure curve
- PP2: intermediate proportional pressure curve
- PP3: highest proportional-pressure curve
- $AUTO_{ADAPT}$ : highest to lowest proportional pressure curve.

The  $AUTO_{ADAPT}$  function enables the circulator to control the pump performance automatically within a defined performance range.

- Adjusting the pump performance to the size of the system.
- Adjusting the pump performance to the variations in load over time.

In proportional pressure  $AUTO_{ADAPT}$  the circulator is set to proportional-pressure control.

### Constant pressure

The head (pressure) is kept constant, irrespective of the heat demand.

The duty point of the circulator will move out or in on the selected constant-pressure curve, depending on the heat demand in the system.



TM06 0705 0814

- CP1: lowest constant-pressure curve
- CP2: intermediate constant-pressure curve
- CP3: highest constant-pressure curve
- $AUTO_{ADAPT}$ : highest to lowest constant-pressure curve.

The  $AUTO_{ADAPT}$  function enables the circulator to control the pump performance automatically within a defined performance range.

- Adjusting the pump performance to the size of the system.
- Adjusting the pump performance to the variations in load over time.

In constant pressure  $AUTO_{ADAPT}$  the circulator is set to constant-pressure control.

### Constant curve

The circulator runs on a constant curve which means that it runs at a constant speed or power.

The duty point of the circulator will move up or down on the selected constant curve, depending on the heat demand in the system.



TM06 0805 0914

Constant curve	UPM3 xx-50 [m]	UPM3 xx-70 [m]
1	2	4
2	3	5
3	4	6
4 (max.)	5	7

### PWM profile A (heating)

The circulator runs on constant speed curves depending on the current PWM value.

The speed decreases when the PWM value increases. If PWM equals 0, the circulator runs at maximum speed.



TM06 0706 0814

PWM profile	UPM3 xx-50 [m]	UPM3 xx-70 [m]
A1	2	4
A2	3	5
A3	4	6
A4 (max.)	5	7

The circulator runs on constant speed curves depending on the current PWM value.

### PWM Profile C (solar)

The circulator runs on constant speed curves depending on the current PWM value.

Speed will increase with increasing PWM value. If PWM equals 0, the circulator stops.



TM06 0707 0814

PWM profile	UPM3 xx-50 [m]	UPM3 xx-70 [m]
C1	2	4
C2	3	5
C3	4	6
C4 (max.)	5	7

## Pump control in heating systems

The heating required in a building varies greatly during the day due to changing outdoor temperatures, solar radiation and heat emanating from people, electric appliances, etc.

Add to this that the need for heating may vary from one section of the building to another and that the thermostatic valves of some radiators may have been turned down by the users. These circumstances will cause an uncontrolled circulator to produce a too high differential pressure when the heat demand is low.

An uncontrolled circulator will produce a too high differential pressure when the heat demand and flow is low.

Possible consequences:

- too high energy consumption
- irregular control of the system
- noise in thermostatic radiator valves and similar fittings.

GRUNDFOS UPM3 HYBRID, UPM3 AUTO and UPM3 AUTO L automatically control the differential pressure by adjusting the pump performance to the actual heat demand, without the use of external components.

### Advantages of pump control

In GRUNDFOS UPM3 HYBRID, UPM3 AUTO and UPM3 AUTO L, pump control is effected by adapting the differential pressure to the flow (proportional-pressure and constant-pressure control). Contrary to an uncontrolled circulator, a constant-pressure-controlled circulator keeps the differential pressure constant. A proportional-pressure-controlled circulator reduces the differential pressure as a result of falling heat demand.

For example:

If the heat demand falls, for instance due to solar radiation, the thermostatic radiator valves will close, and, for the uncontrolled circulator, the flow resistance of the system will rise, for instance from  $A_1$  to  $A_2$ .

In a heating system with an uncontrolled circulator, this situation will cause a pressure rise in the system by  $\Delta H_1$ .

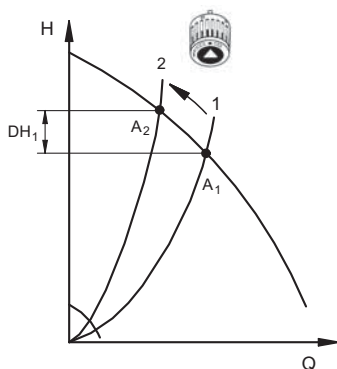

Fig. 16 Uncontrolled circulator

In a system with a proportional-pressure-controlled circulator, operated in the proportional pressure mode the pressure will be reduced by  $\Delta H_2$  and result in reduced energy consumption.

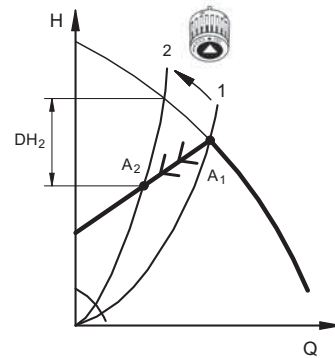

Fig. 17 Circulator operated in proportional-pressure control mode

In a system with an uncontrolled circulator, a pressure rise will often cause flow-generated noise in the thermostatic radiator valves. This noise will be reduced considerably with the proportional pressure control.

TM06 0858 1014

TM06 0857 1014

## AUTO<sub>ADAPT</sub>

If you select AUTO<sub>ADAPT</sub>, the circulator starts with the medium proportional or constant control curve and runs on this curve as long as a new curve will be adapted.

The AUTO<sub>ADAPT</sub> proportional pressure functionality is well known from millions of installed GRUNDFOS trade circulators as ALPHA2 or MAGNA. The AUTO<sub>ADAPT</sub> setting continually analyses and finds the setting where optimal comfort meets minimal energy consumption. It automatically delivers perfect comfort at the lowest possible energy level. It adapts to the requirements of the heating system before reaching the maximum pump curve and allows the circulator to adjust the proportional pressure or constant pressure curve both up and down.

### Advantages of AUTO<sub>ADAPT</sub>

- Easy installation
- Automatic setting
- Demand-controlled operations
- Optimum comfort
- Energy savings
- Reduced CO<sub>2</sub> emissions.

Constant pressure at all load conditions is essential for how well the thermostatic valves can control the heat emission from the radiators. It is a well-known fact that optimum pump control in a two-pipe heating system with thermostatic radiator valves is best obtained by controlling pump pressure on a proportional pressure curve. In systems as underfloor heating or one-pipe systems it might be better to use constant pressure control. However, predicting the best position in real-life applications is rather difficult, because the optimum position depends on correlated factors such as the size of the heating system, the boiler type, the load condition, etc. This is where AUTO<sub>ADAPT</sub> steps in to ensure that the circulator is controlled in an optimum manner.

### The AUTO<sub>ADAPT</sub> algorithm

The objective of the AUTO<sub>ADAPT</sub> algorithm is to measure and analyse the heating system during operation and adapt to the current heating pattern. The system adapts to night vs. day operations, summer vs. winter season, and heat losses or gains affecting room temperature, for example, from radiators, walls and windows, sun radiation, electrical equipment, and people.

### AUTO<sub>ADAPT</sub> three-step task

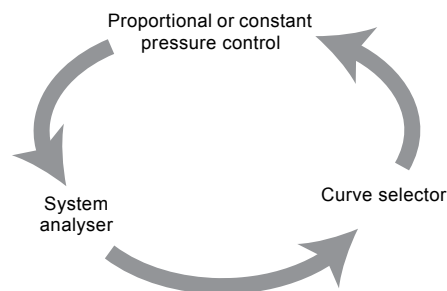

TM06 0786 0914

Fig. 18 The AUTO<sub>ADAPT</sub> three-step task

Basically, AUTO<sub>ADAPT</sub> optimises the position of the proportional or constant pressure curve via a three-step task as illustrated in fig. 18.

The "system analyser" analyses the heating system, which the circulator is a part of. On the basis of the analysis, AUTO<sub>ADAPT</sub> verifies whether the pump pressure is too high, too low, or correct. The "curve selector" then uses this knowledge to select the optimum proportional or constant pressure curve for the circulator. Finally, the circulator is controlled according to the selected proportional or constant pressure curve by means of the "proportional or constant pressure control". The circulator will continue this cycle as long as the circulator is running.

### Example

This example shows proportional pressure AUTO<sub>ADAPT</sub>.

**Note:** The constant pressure AUTO<sub>ADAPT</sub> function will act accordingly just by utilising constant pressure control, and not proportional pressure control as shown in the example below.

The AUTO<sub>ADAPT</sub> function can operate and adjust pump speed according to duty point within a specific area.

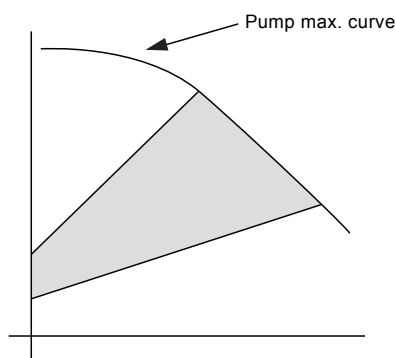

TM06 0848 1014

Fig. 19 Proportional pressure AUTO<sub>ADAPT</sub> operation area

As default the  $AUTO_{ADAPT}$  is preset to operate the circulator on the middle proportional pressure curve. By use of an immediate acting PI-controlling function the circulator will adapt to the system on this proportional pressure curve.

**Note:** The PI controller is set to eliminate any offset within a time frame of 120 seconds.

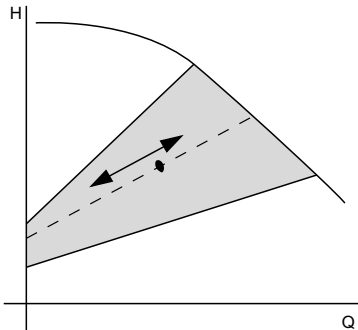

Fig. 20 Proportional pressure control

### System analyser

From the preset reference duty point, the circulator will immediately start to analyse the heating pattern.

The system resistance ( $K_{sys}$ ) is logged and based on this data, a more optimal curve for operation is selected.

**Note:**  $K_{sys} = m^3/h$  to create a system pressure loss of 1 bar.

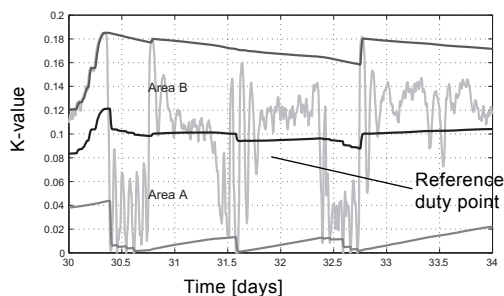

Fig. 21  $K_{sys}$ -values logged for the system analyser

If the actual duty point deviates from the reference duty point over time, the circulator will automatically adjust its performance accordingly. If a tendency of operation in area A is shown, the performance of the circulators is too high. The circulator will then select a lower proportional curve. In other words, if the requirement of the heating system exceeds the reference duty point, the circulator will choose a higher proportional pressure curve. Should the requirement be lower, a lower curve will be chosen.

### Curve selector

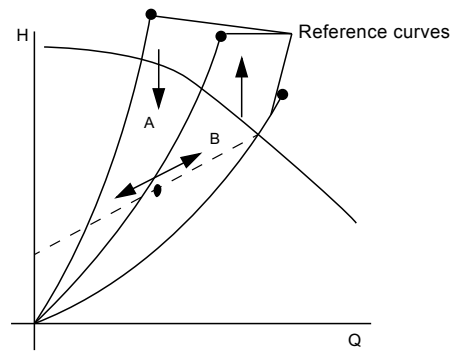

Fig. 22 Duty point on selected proportional pressure curve

**Note:** The arrows symbolise the change of the proportional pressure curve.

### New reference setting

When changing the proportional pressure curve setting to adapt to the requirements of the heating system,  $AUTO_{ADAPT}$  automatically sets a new reference duty point. From the new setting, the process starts over again:  $AUTO_{ADAPT}$  will continuously adapt to changes in the heating pattern.

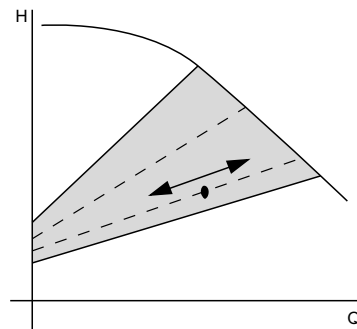







Fig. 23 New lower proportional pressure curve

### Selection of control mode

The selection of the control mode depends on the system type and the allocation of pressure losses defined by the valve or consumer authority.

System type		Recommended control mode
Heating system with PWM control of the circulator.		PWM Profile A 
Solar system with PWM control of the circulator.		PWM profile C 
System without PWM control of the circulator (stand-alone).		Internally controlled
Variable-flow system with relatively high pressure losses inside heating appliance and pipework (> 50 % of pump head).	Two-pipe systems with thermostatic radiator valve with low valve authority.	$H_N > 2$ m for noise reduction. Long distribution pipes. High pressure losses in system parts with total flow. Heat consumers with low pressure losses. Proportional pressure / AUTO <sub>ADAPT</sub> proportional pressure 
	Primary circulator.	Primary circuit with high pressure losses.
Variable-flow system with relatively low pressure losses inside heating appliance and pipework (< 50 % of pump head).	Two-pipe systems with thermostatic radiator valve with high valve authority.	$H_N \leq 2$ m for noise reduction. Former gravity systems. Low pressure losses in system parts with total flow. Heat consumers with high pressure losses. Constant pressure / AUTO <sub>ADAPT</sub> constant pressure 
	Floor heating system with variable flow.	System with thermostatic zone valves.
	One-pipe system with variable flow.	System with thermostatic radiator valves.
	Primary circulator.	Primary circuit with low pressure losses.
	Systems with low flow variation.	Systems with minimum flow ensured by an automatic bypass valve.
Constant flow systems		Constant curve 

## 6. Technical description

### Exploded view

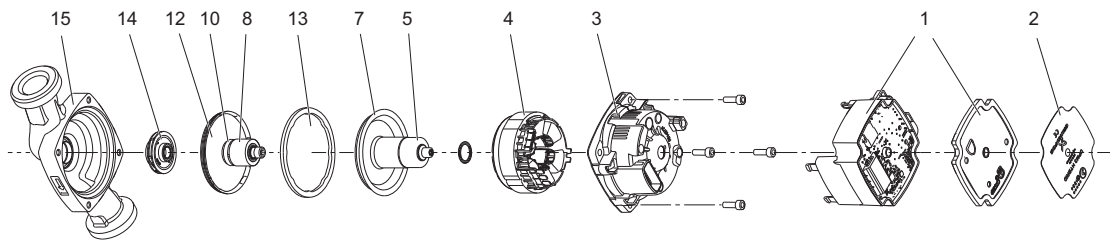

Fig. 24 UPM3 exploded view

TM05 9245 3213

### Sectional drawing

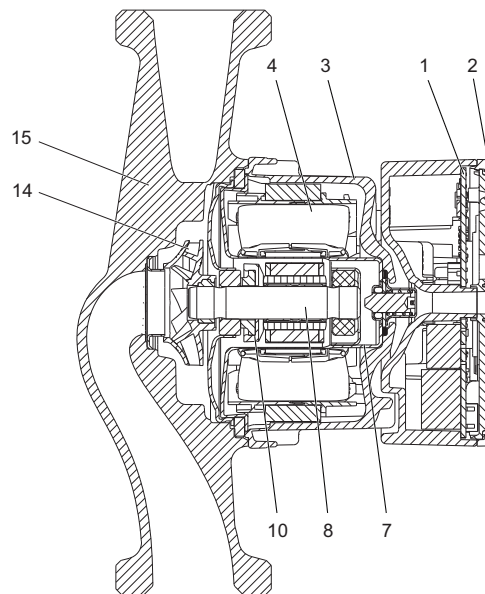

Fig. 25 UPM3 sectional view

TM05 9246 5110



## Material specification

Pos.	Component	Material	EN/DIN
1	Control box	Composite PC-GF10 FR	
	Control electronics	PCB with SMD components	
	Control box heat sink	Aluminium	
2	Front foil	LEXAN 8A13F	
3	Stator housing	Aluminium, silumin	
4	Stator	Copper wire	
	Stator lamination	Laminated iron	
5	Push deblocking device		
	Plunger	Stainless steel	1.4404
	Spring	Stainless steel	1.4310
	Housing for spring	Stainless steel	1.4401
	Guide disc	Stainless steel	1.4401
	Housing for sealing	Stainless steel	1.4401
	Sealing	EPDM	
6	Radial bearing	Ceramics	
7	Rotor can	Stainless steel	1.4401
8	Shaft	Ceramics	
9	Rotor	NdFeB	
	Rotor tube	Stainless steel	1.4521
	Rotor cladding	Stainless steel	1.4401/ 1.4301
	Bush	Stainless steel	1.4301
10	Thrust bearing	Carbon	
	Thrust bearing retainer	EPDM	
11	Screws	Steel, eco-lubric coated	
12	Bearing plate	Stainless steel	1.4301
13	Gasket	EPDM	
14	Impeller	Composite/PES 30 % GF	
15	Pump housing	Cast iron GG15	EN-GJL-150
16	Neck ring	Stainless steel	1.4301

## Description of components

The Grundfos UPM3 circulators are of the canned-rotor type as circulator and motor form an integral unit without shaft seal and with only one gasket for sealing and four screws for fastening the stator housing to the pump housing. The bearings are lubricated by the pumped liquid as the rotor can is filled with water. The focus has been on using eco-friendly materials as well as on limiting the number of materials.

### Motor description

The efficiency of the three-phase, 4-pole, synchronous, electronically commutated permanent-magnet (ECM/PM) motor type is considerably higher compared to a conventional asynchronous squirrel-cage motor.

The ECM/PM motor is designed according to the canned-rotor principle. The design of the mechanical motor components has mainly focused on these features:

- reliable with stainless steel rotor can in one part and a specific formed EPDM gasket
- simple design meaning as few components as possible, each with several functions
- high efficient due to permanent magnets and low-friction bearings.

The motor is cooled by the pumped liquid which reduces the sound pressure level to a minimum. Being software-protected, the circulator requires no further motor protection.

### Stator housing

The aluminium die-cast stator housing with four fixing holes is following the design of the well-accepted Grundfos UP pumps. It enables easy change of motor positions by removing the four screws holding the stator housing and turning the housing to the desired position. There are two versions: one without drain hole as IP44, and one with one drain hole in two possible positions as IPX4D. During operation, the drain hole must always point downwards. UPM3 is IP44 as standard and IPX4D as an option for condensing applications.

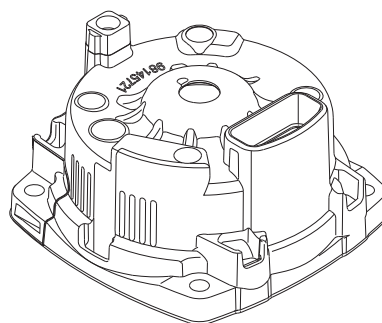

Fig. 26 Stator housing

TM05 9258 3613

### Stator and windings

The UPM3 have a three-phase stator with six concentric positioned in-slot windings.

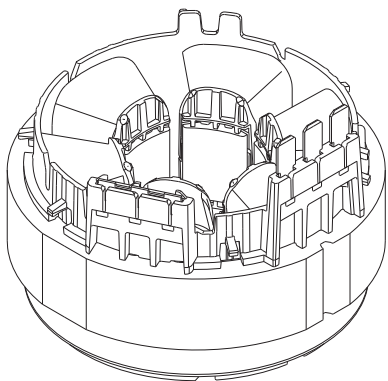

Fig. 27 Stator

TM05 9260 3613

### Rotor can

The rotor can is drawn out of one sheet of stainless-steel. It contains the grinded and honed upper radial bearing. On top the rotor can has a hole on which the deblocking device is welded.

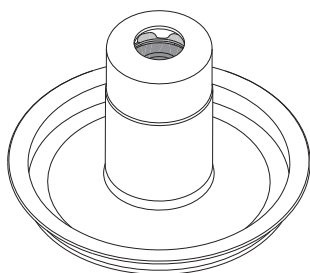

Fig. 28 Rotor can with bearing holder and ceramic bearing

TM05 9247 3613

### Deblocking device

The deblocking device consists of an axial moving plunger tightened by an O-ring and pulled back by a spring inside a stainless steel housing that is welded to the rotor can. The deblocking device is designed for circulators integrated in appliances to give access to the shaft from the front of the circulator without demounting the control box.

By pushing and turning a screw driver, Phillips No. 2, the plunger pushes the shaft in axial direction into the circulator, while it can be turned as well. The force is high enough to deblock circulators which are seized by lime e.g. if an appliance is stored for months after being wet tested. Before, during and after the deblocking, the device is tight and must not release any water.

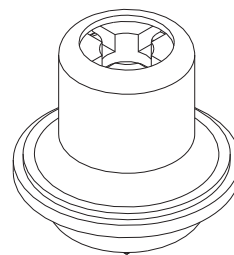

Fig. 29 Deblocking device

TM05 9253 3613

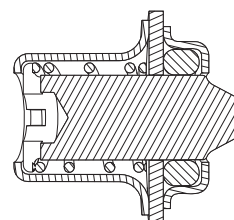

Fig. 30 Sectional drawing of deblocking device

TM06 02915013

### Shaft with rotor

The shaft is made of ceramics. To avoid precipitation of calcium in the radial bearings, the shaft has been plunge-ground at the journal bearings. It has a through-going hole to ensure good lubrication and cooling of the upper bearing. The rotor can does not need to be vented as air inside the rotor chamber will escape the system through the through-going hole of the shaft.

The rotor core is made of bonded neodymium permanent magnets. The rotor is encapsulated in a thin stainless-steel cladding welded to the end covers. The rotor is fixed on the shaft by a back iron with a bush. After assembly the whole unit is balanced.

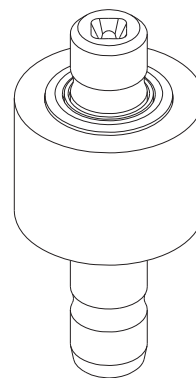

Fig. 31 Shaft with rotor

TM03 9250 3613

**Thrust bearing**

The antimony-free carbon thrust bearing is fitted to the shaft in a flexible EPDM retainer.

In combination with the bearing plate, the thrust bearing prevents forces from being transmitted axially to rotor and rotor can.

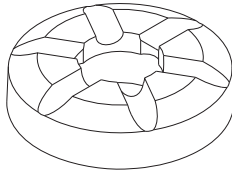

TM05 9252 3613

**Fig. 32** Thrust bearing

**Bearing plate**

The bearing plate is made of stainless steel. The grinded and honed inner radial and axial ceramic bearing is pressed into the bearing plate. The axial bearing is lapped to reduce any friction and the run in period of the circulator. Due to the relatively large bearing plate surface, the motor heat is effectively carried away by the pumped liquid. Five tiny laser holes through the bearing plate ensure optimum venting and minimise the gradual replacement of rotor liquid with the pumped liquid. The bearing plate is made of stainless steel. The ground and honed inner radial bearing is pressed into the bearing plate. Due to the relatively large bearing plate surface, the motor heat is effectively carried away by the pumped liquid. The four holes of the bearing plate ensure optimum venting and minimise the gradual replacement of rotor liquid with the pumped liquid.

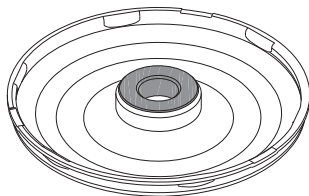

TM05 9249 3613

**Fig. 33** Bearing plate with ceramic bearing

**Impeller**

The composite impeller is of the radial type with curved blades. The impeller shaft with rotor and bearing plate is assembled in one unit to eliminate possible misalignment in the bearings.

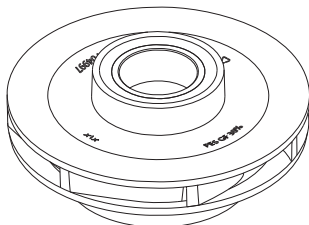

TM05 9251 3613

**Fig. 34** Impeller

**Running unit**

The unit is a pre-mounted combination of shaft with rotor, thrust bearing with retainer, bearing plate and impeller. The running unit is inserted into the rotor can with the upper radial bearing. The unit runs as a bearing system, ceramic/ceramic, with almost no wear as long as it is lubricated. During production the unit is lubricated with glycerine. When the unit is mounted in a water-filled system, the system water lubricates the bearings. This guarantees the extremely reliable Grundfos ceramic bearing system of wet-running circulators.

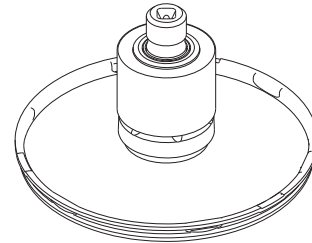

TM05 9256 3613

**Fig. 35** Running unit

**Gasket**

The gasket is a formed flat O-ring made of EPDM, which is applicable for drinking water as well. The gasket seals up stator housing, pump housing, rotor can and bearing plate.

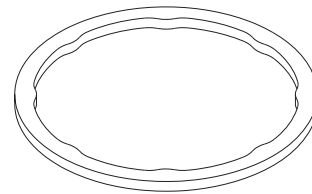

TM05 9257 3613

**Fig. 36** Gasket



TM06 0846 1014

**Fig. 37** Sectional drawing showing sealing principle of gasket

### Pump housing

As standard, the pump housing is available in electro-coated cast iron with threaded suction and discharge ports. The pump housing is of the in-line type. The stainless-steel neck ring is pressed into the pump housing to minimise the amount of liquid running from the discharge side of the impeller to the suction side. UPM3 versions with OEM-specific housings are available on request.

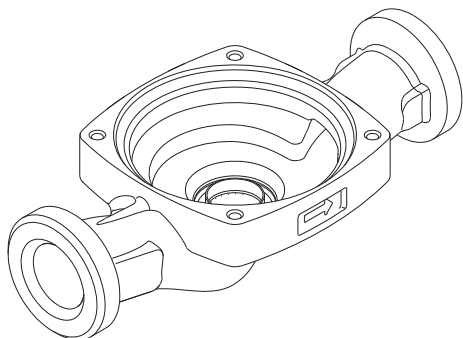

TM05 9254 3613

Fig. 38 Pump housing

### Control box

The UPM3 control box housing is made of two composite parts welded together with an aluminium heat sink on top and covered by a front foil which cannot be removed. Power and signal connectors are integrated. There are two versions available with signal connection designed for Grundfos UPER/UPM connector or TE Mini Superseal connector.

The control box contains the PCBs for internal power supply, control and communication. The control box includes all relevant functions and EMC filter components. It is available with different hard- and software, mainly different regarding internal or external control, with or without user interface and communication signal as PWM.

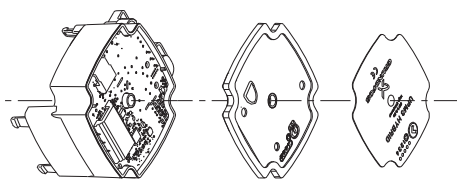

TM06 0826 1014

Fig. 39 Control box

## 7. Installation

### Mechanical installation

Mounting dimensions can be found in the data sheets.

Arrows on the pump housing indicate the liquid flow direction through the circulator. The circulator is designed to be installed with horizontal shaft pumping upwards, downwards or horizontally.

**Note:** The circulator must always be installed with horizontal motor shaft within  $\pm 5^\circ$ .

The circulator should be installed in the system in such a way that no major amount of air flowing through the circulator or gathering in the pump housing will affect the circulator when it is out of operation. If, in addition, a non-return valve is installed in the flow pipe, there is a high risk of dry running as the air cannot pass the valve.

### Control box positions

The terminal box has been designed to avoid the necessity of turning the terminal box, which gives access to the terminals from the front. If necessary, you can turn the pump head with terminal box in steps of 90 degrees to all four options. Please notice that you turn the user interface of the UPM3 HYBRID as well. As standard the user interface is on top (12 h), if the terminals are in position 9 h. You can choose to have the orientation of the front foil in four different positions. In this way, the nameplate is always in horizontal position when the circulator is mounted.

### Changing the control box position

To change the control box position, do as follows:

1. Remove the screws holding the pump head.
2. Turn the control box to the desired position.
3. Replace the screws and tighten securely. The nameplate position cannot be changed.

**Note:** Before any dismantling of the circulator, the system must be drained, or the isolating valves on either side of the circulator must be closed.

### Insulation

When insulating the circulator, the front plate of the control box must not be covered in order to allow cooling by the surrounding air.

If the circulator is installed inside a cabinet, a boiler or a heating kit encapsulated with insulation shells, the inside air temperature has to be evaluated and must not be higher than 70 °C during operation.

### Ambient temperature

The ambient temperature must not exceed 70 °C (measured in a distance of not more than 5 cm in front of the front foil at its lower edge).

**Note:** The dew point of the air at ambient temperature should always be lower than the liquid temperature, otherwise condensation may form in the stator housing.

### Relative air humidity

The relative air humidity must not exceed 95 % in a non-condensing environment.

### Storage temperature

-40 to +75 °C.

### Medium temperature

UPM3 with cast iron housing: max. 110 °C

UPM3 with composite housing (PA 6.6): max. 95 °C

Ambient temp. °C	Medium temp. max °C
0	110
10	110
20	110
30	110
40	110
55	110
60	90
65	80
70	70

**Note:** For life time evaluation, the temperature profile needs to be defined.

### Inlet pressure

To avoid cavitation noise and damage to the pump bearings, the following minimum pressures are required at the pump suction port.

Liquid temperature	75 °C	95 °C	110 °C
Pressure	0.005 MPa 0.05 Bar	0.05 MPa 0.5 Bar	0.108 MPa 1.08 Bar

## Electrical installation

The electrical connection and protection must be carried out in accordance with local regulations.

- The circulator requires no external motor protection.
- Check that the supply voltage and frequency correspond to the values stated on the nameplate.
- The circulator must not be used with an external speed control which varies the supply voltage.
- If an earth leakage circuit breaker is used, check which type it is.
- If an external relay is used, check if it can stand the inrush current.

### Supply voltage

1 x 230 V + 10 %/- 15 %, 50 Hz.

The UPM3 circulators are externally controlled via PWM signal or internally speed-controlled by a frequency converter. Therefore, the circulators must not be used with an external speed control which varies the supply voltage for example phase-cut or pulse-cascade control.

### Reduced supply voltage

The pump operation is ensured above 160 VAC with reduced performance.

UPM3 with PWM control: If the voltage falls below the specified voltage range, a low voltage warning is sent via PWM return signal.

UPM3 in internal control mode: If the voltage falls below the specified voltage range, a low voltage warning is shown. If it falls below the minimum voltage, the circulator stops and shows alarm.

### Earth leakage circuit breaker (ELCB)

If the circulator is connected to an electric installation that uses an earth leakage circuit breaker (ELCB) as additional protection, this circuit breaker must trip when earth fault currents with DC content (pulsating DC) occur.

The earth leakage circuit breaker must be marked with the first (type A) or both (type B) of the symbols shown below:



Fig. 40 Symbol on earth leakage circuit breaker

### Leakage current

The pump mains filter will cause a discharge current to earth during operation.

Leakage current: < 3.5 mA.

### High-voltage test

The circulator incorporates filter components that are connected to protective earth. Therefore, a standard high-voltage test **cannot** be made without damaging the filters.

## Inrush current

All electronic circulators contain electronic units that must be protected by filters including capacitors and ECM circulators frequency converters with AC/DC rectifiers containing capacitors to equalize the waves. This is not the case in most asynchronous circulators.

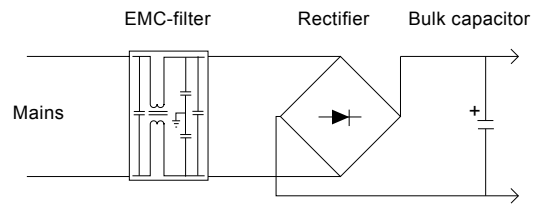

TM06 0822 1014

Fig. 41 Rectification of VAC voltage to DC voltage

The load of electronically commutated motors (ECM) behaves as a capacitive load and not as a motor load like in a standard circulator.

At start, the capacitor is unloaded. Hereby the amplitude of the current peak depends on the grid impedance, until the capacitor is charged. The faster the capacitor is charged, the higher amplitude, and the faster the circulator can be started. After this period of time, the current will drop to the rated current.

**Definition:** Inrush current is the current peak charging the capacitors in the electronics when the supply voltage is connected.

**Note:** When discussing measurements, it is important to refer to the same method. Since 2007, Grundfos uses the IEC 61000-3-3 Annex B method for measuring inrush current.

The inrush current peak charges the bulk capacitor to 325 VDC as fast as the power grid allows. That shows that inrush current is not only depending on the integrated electronics but as well on the impedance of the grid.

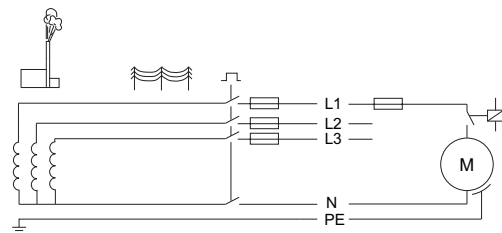

TM06 0819 1014

If you use a relay to switch the power supply of the circulator, you risk excessive wear on the relay contact surface.

To avoid such problems there are different external and internal solutions.

**External solutions in the controller of the appliance unit**

- Specific relays with silver tin oxide (AgSnO<sub>2</sub>) inrush relay contacts.
- Switching at ZERO crossing.
- Standby operation - circulator only switches via the PWM signal.

**Internal solutions in the circulator**

- NTC resistor in the power input circuit (passive)
- Bypass relay with PTC resistor, controlled by the electronics (active)

UPM3 circulators are available with different hardware:

**NTC resistor (passive - option for UPM3)**

We recommend that you use this option for circulators that are permanently connected to the grid and switched on/off by external PWM signal.

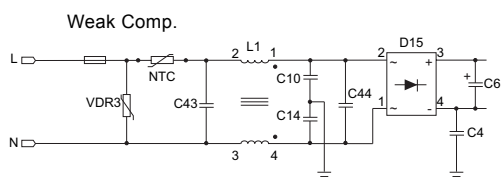

Fig. 42 NTC

At startup the operating temperature of the circulator including the NTC resistor is cold. In this situation the NTC resistor has a high resistance and is able to limit the inrush current down to ~ 10 A.

During operation the operating temperature of the circulator including NTC resistor is hot. There is no inrush current but the NTC resistance decreases so that the loss is limited.

**Note:** At restart, the operator must ensure that the NTC resistor has been cooled down so that an efficient operation is guaranteed. Normally, it takes 1 minute to cool down the resistor.

When the power supply to the circulator is switched on and off via an external relay, you must ensure that the contact material of the relay is able to handle higher inrush currents.

**Relay and PTC (active - standard for UPM3 HYBRID variants)**

We recommend that you use this option for circulators that are not in permanent operation and can be interrupted by a relay of the controller of the appliance.

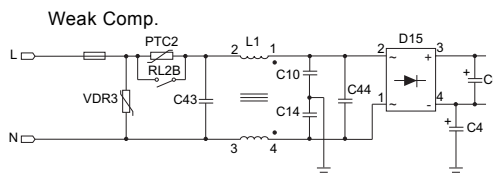

Fig. 43 Relay and PTC

At startup the relay is open. In this mode the PTC resistor is able to limit the inrush current down to a level of approximately 4 A.

During operation the relay is closed. In this mode the resistor is by-passed so that efficient operation is guaranteed.

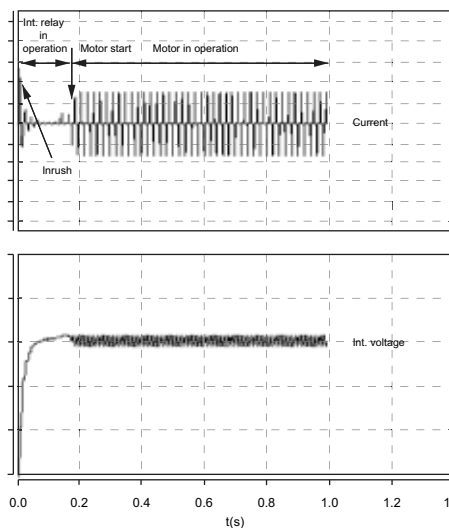

Fig. 44 Example: UPM3 with internal inrush relay

**Note:** The inrush current is measured on a flicker network according to IEC 61000-3-3:1994 + A1, + A2, Annex B.

TM06 0820 1014

TM06 0821 1014

TM06 0823 1014

## Power supply connection

The circulator must be connected to the power supply with the TE Superseal connector. Adapters are available for the use of cables with Molex or Volex connectors.

### TE Superseal power connector

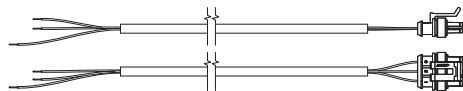

TM06 0608 0514

Fig. 45 TE Superseal power connector

### Reliability

- Temperature/fireproofed glow wire material
- Waterproofed.

### Safety

- Additional locking latch with pull-out force > 100 N
- Lock to be opened only with a screw driver

### Availability

- Worldwide as TE standard.

## Control signal connection

UPM3 circulators are externally speed-controlled. You need a signal cable to enable the pump control, otherwise the circulator with profile A will always run at maximum speed and the circulator with profile C will stop.

UPM3 HYBRID circulators are either internally or externally speed-controlled.

If you set the circulator to external control mode (PWM profile A or C) via the user interface, you need a signal cable as well. If you set the circulator to internal control mode, there is a blind plug available to close the signal connection. The plug is not required for safety reasons.

The signal cable connection has three leads: signal input, signal output and signal ref. The cable must be connected to the control box either by FCI or TE Mini Superseal plug. The optional signal cable can be supplied with the circulator as an accessory.

The cable length can be customised to specific requirements (max. 3 m).

### TE Mini Superseal

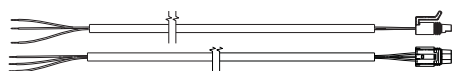

TM06 0610 0514

Fig. 46 TE Mini Superseal and FCI connector

### Safety

- Additional locking latch with pull-out force > 100 N.
- Lock to be opened only with a screw driver.

### Availability

- Worldwide as TE standard.

### Grundfos FCI (used for UPER/UPM)



TM06 0610 1514

Fig. 47 Cable connections and position of the leads

### Backwards compatibility

- For replacement of UPER/UPM circulators or in appliances which use FCI plug, e.g. cable trees.

### Safety

- Two-part design - separate lock is needed to meet the pull force requirements > 100 N.

### Availability

- Many cable suppliers use these cable connections.



## Overview of technical data

Feature	Specification
CE mark	EMC Directive (2004/108/EC)
Conformity with following relevant EC Directives	Standards used: EN 61000-6-2:2005, EN 61000-6-3:2007, EN 55014-1:2006, EN 55014-2:1997, Low Voltage Directive (2006/95/EC)
Ecodesign ErP ready 2015	Standards used: EN 60335-1:2012, EN 60335-2-51:2003 + A1, Ecodesign Directive (2009/125/EC)
REACH compliancy	Standards used: EN 16297-1:2012, -2:2012, -3:2012
WEEE compliancy	Fulfilling Ecodesign requirements in 2015, EEI ≤ 0.20, EN16297/3 or -/2
RoHS compliancy	REACH Directive 1907/2006 (see page 55)
VDE Approval	WEEE Directive 2012/19/EU (see page 55)
VDE code	Circulators are not in scope
Enclosure class:	RoHS Directive 2011/65/EU (see page 55)
TF class	VDE certificate: No. 40039416 (see page 54)
High voltage protection	It proves the conformity with the essential safety requirements of the EC Low Voltage Directive (2006/95/EC) including amendments.
Drinking water approvals (WRAS, KTW, DVGW W270, etc.)	GFNJB and GFNJC
Feature	Specification
IP44 (standard without drain holes). Option: IP X4D (with drain hole)	
TF110 at 70 °C ambient temperature	
EN 60335-1 1000 VAC	
All pump head components will be compliant	
Specific compliant pump housings will be available	
Feature	Specification
Continuously restarting after 1.33 seconds with max. torque	
Manual deblocking device, access from front side	
1 minute (3 x 20 seconds), all circulators will be lubricated with glycerine	
Rotor can filled with water: fulfils EN 60335-2-51	
> 100,000 h (with specified load profile)	
> 500,000 cycles	
With NTC: 1 min, with relay. No specific requirements	
Available depending on the housing, accuracy: see PWM specification	
With relay: < 4 A, With NTC: < 10 A	
I (EN 60335-1)	
F (EN 60335-1)	
≤ 3.5 mA (EN 60335-1)	
563 to 5,991 min <sup>-1</sup> (depending on the variant)	
70 °C	
95 °C on composite housings, 110 °C on cast iron housings	
1 MPa (10 bar) (depending on the housing material)	
0.05 MPa (0.5 bar) at 95 °C liquid temperature	
0 °C (IP44: above dew point of ambient air)	
160 VAC (with reduced performance)	
The motor is protected by the electronics in the control box and requires no external motor protection.	
Temperature = 130 °C, (for peak ≤ 30 min)	
EU: 1 x 230 V + 10 %/- 15 %, 50 Hz	
< 1.5 seconds for cold start, warm start and speed change	
< 3.3 seconds for cold start, warm start and speed change	
Maximum 95 %, non-condensing environment.	
-40 to +75 °C	

## 8. Startup

Before you start the UPM3 circulator, do as follows:

1. Mount the circulator in the right way (see *7. Installation*)
2. Check that the unions are tightened
3. Check that the valves are opened
4. Fill the system and vent it above the circulator
5. Check if the required minimum inlet pressure is available at the pump inlet.
6. Switch on the power supply
7. If the circulator is externally controlled, check if the system controller sends a signal to the circulator which controls the speed or might even stop the circulator.
8. If the circulator is internally controlled, the circulator starts with factory pre-setting (e.g. proportional pressure curve 3). Change the setting if necessary (see *User interface*)

***Do not start the pump until the system has been filled with liquid and vented.***

Caution

***Being self-venting, UPM3 does not require to be vented before startup. Air inside the pump will be transported by the medium into the system during the first minutes after pump startup.***

### ***Warning***

***The use of this product requires experience with and knowledge of the product.***



***Persons with reduced physical, sensory or mental capabilities must not use this product, unless they are under supervision or have been instructed in the use of the product by a person responsible for their safety.***

***Children must not use or play with this product.***

## 9. Disposal

This product or parts of it must be disposed of in an environmentally sound way:

- Use the public or private waste collection service.
- If this is not possible, contact the nearest Grundfos company or service workshop.

## 10. Control box positions

Different positions of the control box are available and must be defined as follows:

- For IP44 versions without drain holes, all positions are allowed.
- For IPX4D versions with drain holes, the drain hole must point downwards after installation. Only connector positions to the side are possible.

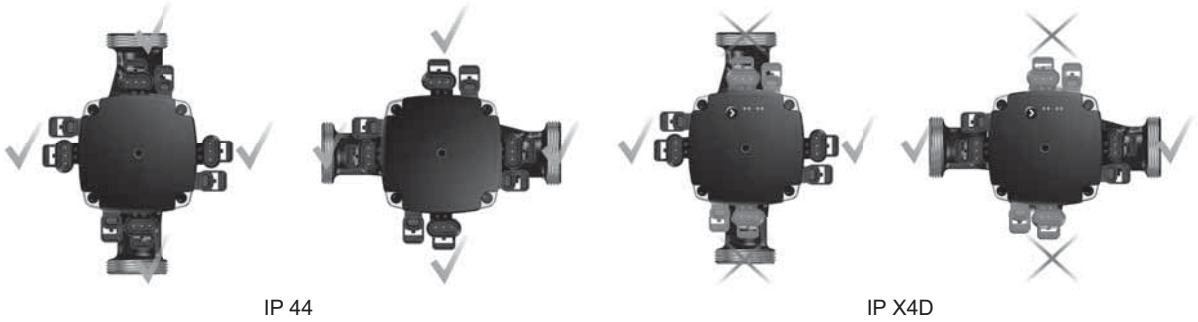

TM06 0855 1014

# 11. Dimensions (standard housings)

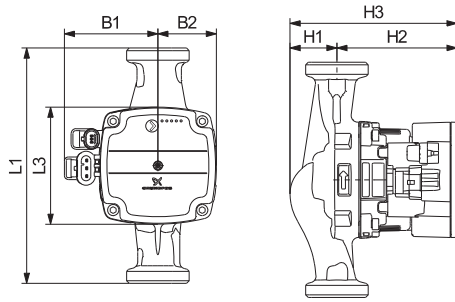

TM05 8555 0613

Pump type	Dimensions [mm]							Connections	Weight [kg]
	L1	L3	B1	B2	H1	H2	H3		
UPM3 15-75 130	130	90	72	45	36	92	128	G 1	1.8
UPM3 25-75 130	130	90	72	45	36	92	128	G 1 1/2	1.9
UPM3 25-75 180	180	90	72	45	36	92	128	G 1 1/2	2.0
UPM3 15-70 130	130	90	72	45	36	92	128	G 1	1.8
UPM3 25-70 130	130	90	72	45	36	92	128	G 1 1/2	1.9
UPM3 25-70 180	180	90	72	45	36	92	128	G 1 1/2	2.0
UPM3 15-60 130	130	90	72	45	36	92	128	G 1	1.8
UPM3 25-60 130	130	90	72	45	36	92	128	G 1 1/2	1.9
UPM3 25-60 180	180	90	72	45	36	92	128	G 1 1/2	2.0
UPM3 15-50 130	130	90	72	45	36	92	128	G 1	1.8
UPM3 25-50 130	130	90	72	45	36	92	128	G 1 1/2	1.9
UPM3 25-50 180	180	90	72	45	36	92	128	G 1 1/2	2.0
UPM3 15-40 130	130	90	72	45	36	92	128	G 1	1.8
UPM3 25-40 130	130	90	72	45	36	92	128	G 1 1/2	1.9
UPM3 25-40 180	180	90	72	45	36	92	128	G 1 1/2	2.0
UPM3 FLEX AC 15-70 130	130	90	72	45	36	92	128	G 1	1.8
UPM3 FLEX AC 25-70 130	130	90	72	45	36	92	128	G 1 1/2	1.9
UPM3 FLEX AC 25-70 180	180	90	72	45	36	92	128	G 1 1/2	2.0
UPM3 FLEX AS 15-70 130	130	90	72	45	36	92	128	G 1	1.8
UPM3 FLEX AS 25-70 130	130	90	72	45	36	92	128	G 1 1/2	1.9
UPM3 FLEX AS 25-70 180	180	90	72	45	36	92	128	G 1 1/2	2.0
UPM3 AUTO L 15-70 130	130	90	72	45	36	92	128	G 1	1.8
UPM3 AUTO L 25-70 130	130	90	72	45	36	92	128	G 1 1/2	1.9
UPM3 AUTO L 25-70 180	180	90	72	45	36	92	128	G 1 1/2	2.0
UPM3 AUTO L 15-50 130	130	90	72	45	36	92	128	G 1	1.8
UPM3 AUTO L 25-50 130	130	90	72	45	36	92	128	G 1 1/2	1.9
UPM3 AUTO L 25-50 180	180	90	72	45	36	92	128	G 1 1/2	2.0
UPM3 AUTO 15-70 130	130	90	72	45	36	92	128	G 1	1.8
UPM3 AUTO 25-70 130	130	90	72	45	36	92	128	G 1 1/2	1.9
UPM3 AUTO 25-70 180	180	90	72	45	36	92	128	G 1 1/2	2.0
UPM3 AUTO 15-50 130	130	90	72	45	36	92	128	G 1	1.8
UPM3 AUTO 25-50 130	130	90	72	45	36	92	128	G 1 1/2	1.9
UPM3 AUTO 25-50 180	180	90	72	45	36	92	128	G 1 1/2	2.0
UPM3 HYBRID 15-70 130	130	90	72	45	36	92	128	G 1	1.8
UPM3 HYBRID 25-70 130	130	90	72	45	36	92	128	G 1 1/2	1.9
UPM3 HYBRID 25-70 180	180	90	72	45	36	92	128	G 1 1/2	2.0
UPM3 HYBRID 15-50 130	130	90	72	45	36	92	128	G 1	1.8
UPM3 HYBRID 25-50 130	130	90	72	45	36	92	128	G 1 1/2	1.9
UPM3 HYBRID 25-50 180	180	90	72	45	36	92	128	G 1 1/2	2.0

Other versions or housings with different dimensions, materials, design or functionality are available on request. Please contact your Grundfos HVAC OEM Key Account Manager.

## 12. Performance curves, technical data

### Curve conditions

The guidelines below apply to the performance curves on the following pages:

- Test liquid: airless water.
- The curves apply to a density of 983.2 kg/m<sup>3</sup> and a liquid temperature of +20 °C.
- All curves show average values and should not be used as guarantee curves. If a specific minimum performance is required, individual measurements must be made.
- The curves apply to a kinematic viscosity of 0.474 mm<sup>2</sup>/s (0.474 cSt).
- The conversion between head H [m] and pressure p [kPa] has been made for water with a density of 1000 kg/m<sup>3</sup>. For liquids with other densities, e.g. hot water, the discharge pressure is proportional to the density.
- Curves obtained according to EN 16297.

- UPM3 with PWM signal connection are designed to be speed controlled by an external system controller. Therefore, EEI and P<sub>L,Avg</sub> of the different pump heads (circulators without pump housings) are measured to be in compliance with the Ecodesign requirements of regulation EC/622/2012 with a reference housing in accordance with EN 16297-3.
- It is not obligatory to show P<sub>L,Avg</sub> but it gives an indication on the yearly expectable average power consumption.
- The performance of PWM controlled pumps is measured with A profile (heating) at eight PWM values: 5 % (max.), 20 %, 31 %, 41 %, 52 %, 62 %, 73 %, 88 % (min.).
- C profile curves are measured mirrored with 95 % (max.), 80 %, 69 %, 59 %, 48 %, 38 %, 27 %, 12 % (min.).
- Maximum curves are limited by speed and power
- Variants with two different minimum curves are available: minimum curve A (standard) at approximately 0.1 m and minimum curve B (option) at approximately 1 m.

Pump type	P <sub>1</sub> max. nom. [W]	Speed max. nom. [min <sup>-1</sup> ]	Speed min. nom.	EEI Part 2 or 3	P <sub>L,Avg</sub> [W]
UPM3 xx-75	60	5991	A 563 / J 2025	≤ 0.20	≤ 28
UPM3 xx-70	52	5766	A 563 / J 2025	≤ 0.20	≤ 23
UPM3 xx-60	39	5288	A 563 / J 2025	≤ 0.20	≤ 18
UPM3 xx-50	33	4838	A 563 / J 2025	≤ 0.20	≤ 16
UPM3 xx-40	25	4360	A 563 / J 2025	≤ 0.20	≤ 12
UPM3 FLEX AC xx-70	52	5766	A 563 / J 2025	≤ 0.20	≤ 23
UPM3 FLEX AS xx-70	52	5766	A 563 / J 2025	≤ 0.20	≤ 23
UPM3 AUTO L xx-70	52	5766	A 563 / J 2025	≤ 0.20	≤ 25
UPM3 AUTO L xx-50	33	4838	A 563 / J 2025	≤ 0.20	≤ 16
UPM3 AUTO xx-70	52	5766	A 563 / J 2025	≤ 0.20	≤ 25
UPM3 AUTO xx-50	33	4838	A 563 / J 2025	≤ 0.20	≤ 16
UPM3 HYBRID xx-70	52	5766	A 563 / J 2025	≤ 0.20	≤ 25
UPM3 HYBRID xx-50	33	4838	A 563 / J 2025	≤ 0.20	≤ 16

# 13. Data sheets

## UPM3 15-75 130, 25-75 130, 25-75 180

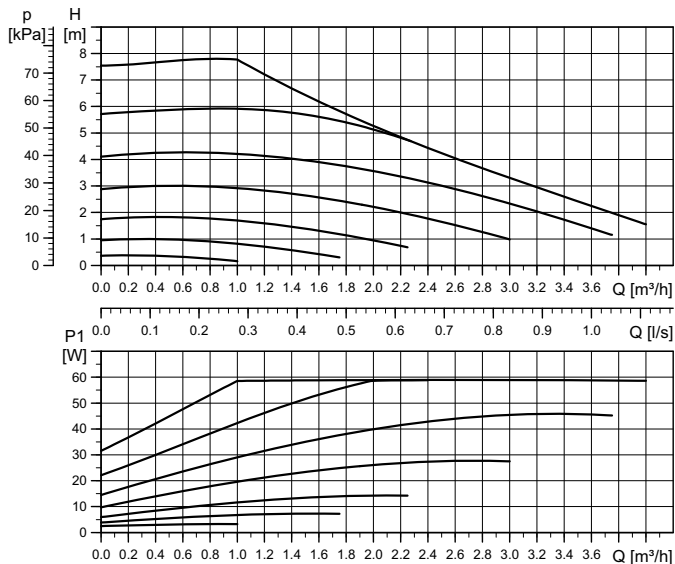

High efficiency

Ready for Ecodesign 2015

$E_{EE} \leq 0.20$  Part 3  
 $P_{L,avg} \leq 28$  W

TM06 0580 0814

Performance curve

Electrical data, 1 x 230 V, 50 Hz		
Speed	$P_1$ [W]	$I_{1/1}$ [A]
Min.	2	0.04
Max.	60	0.58

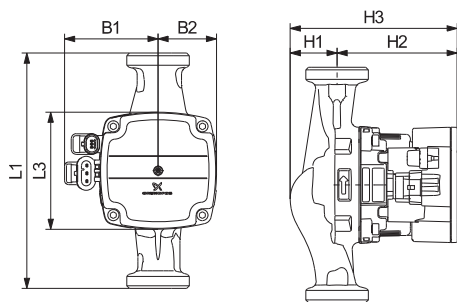

TM06 0697 0714

Dimensions



TM06 0785 0914

Control box position

Pump type	Dimensions [mm]							Connections	Weight [kg]
	L1	L3	B1	B2	H1	H2	H3		
UPM3 15-75 130	130	90	72	45	36	92	128	G 1	1.8
UPM3 25-75 130	130	90	72	45	36	92	128	G 1 1/2	1.9
UPM3 25-75 180	180	90	72	45	36	92	128	G 1 1/2	2.0

### Technical data

System pressure	Max. 1.0 MPa (10 bar)	Enclosure class	IP44 (non-condensing)
Minimum inlet pressure	0.05 MPa (0.50 bar) at 95 °C liquid temperature	Motor protection	No external protection needed
Liquid temperature	+2 °C to +110 °C (TF110)	Approval and marking	VDE, CE

### UPM3 15-70 130, 25-70 130, 25-70 180

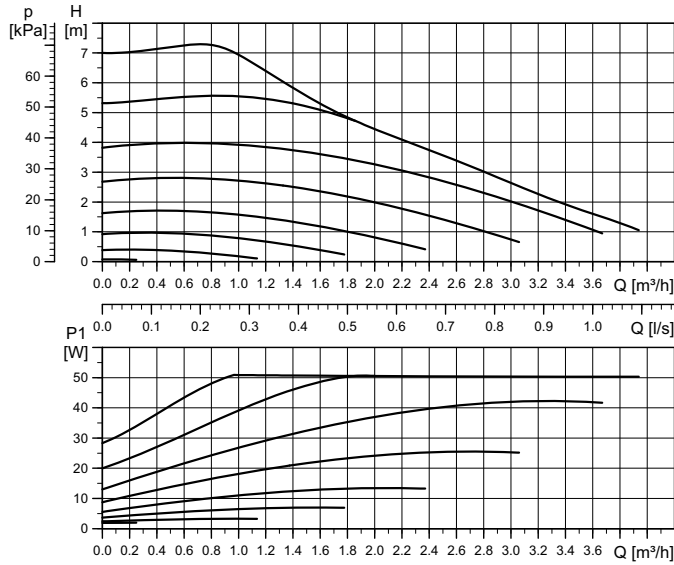

High efficiency

Ready for Ecodesign 2015

EEI ≤ 0.20 Part 3

$P_{L,avg} \leq 23 \text{ W}$

TM06 0579 0814

Performance curve

**Electrical data, 1 x 230 V, 50 Hz**

Speed	$P_1$ [W]	$I_{1/1}$ [A]
Min.	2	0.04
Max.	52	0.52

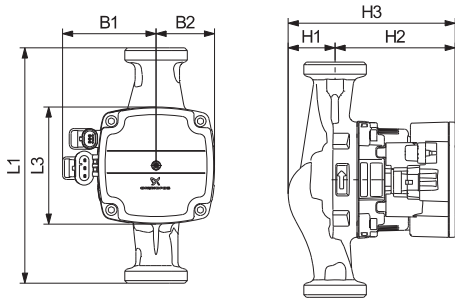

TM06 0697 0814



TM06 0785 0914

Dimensions

Control box position

Pump type	Dimensions [mm]							Connections	Weight [kg]
	L1	L3	B1	B2	H1	H2	H3		
UPM3 15-70 130	130	90	72	45	36	92	128	G 1	1.8
UPM3 25-70 130	130	90	72	45	36	92	128	G 1 1/2	1.9
UPM3 25-70 180	180	90	72	45	36	92	128	G 1 1/2	2.0

**Technical data**

<b>System pressure</b>	Max. 1.0 MPa (10 bar)	<b>Enclosure class</b>	IP44 (non-condensing)
<b>Minimum inlet pressure</b>	0.05 MPa (0.50 bar) at 95 °C liquid temperature	<b>Motor protection</b>	No external protection needed
<b>Liquid temperature</b>	+2 °C to +110 °C (TF110)	<b>Approval and marking</b>	VDE, CE



UPM3 15-60 130, 25-60 130, 25-60 180

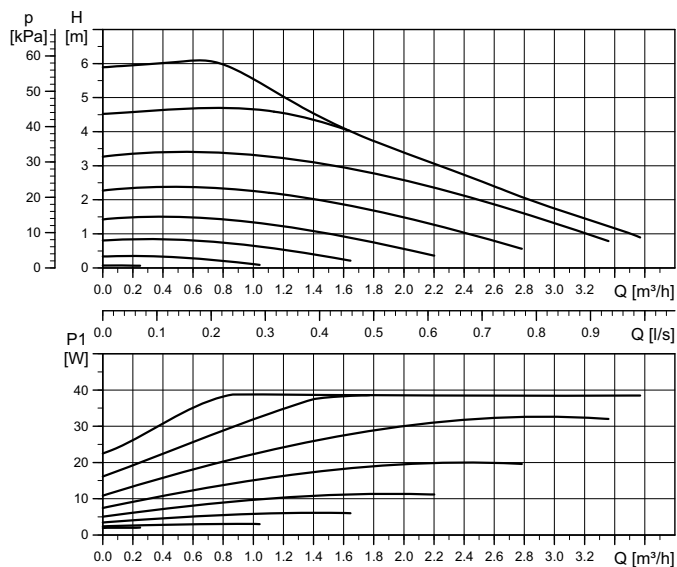

High efficiency

Ready for Ecodesign 2015

EEI ≤ 0.20 Part 3

P<sub>L,avg</sub> ≤ 18 W

UPM3 15-60 130, 25-60 130, 25-60 180

TM06 0578 0814

Performance curve

Electrical data, 1 x 230 V, 50 Hz		
Speed	P <sub>1</sub> [W]	I <sub>1/1</sub> [A]
Min.	2	0.04
Max.	39	0.42

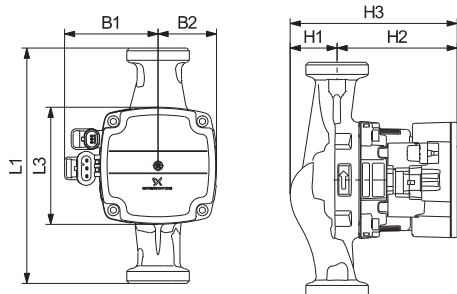

TM06 0697 0814



TM06 0785 0914

Dimensions

Control box position

Pump type	Dimensions [mm]							Connections	Weight [kg]
	L1	L3	B1	B2	H1	H2	H3		
UPM3 15-60 130	130	90	72	45	36	92	128	G 1	1.8
UPM3 25-60 130	130	90	72	45	36	92	128	G 1 1/2	1.9
UPM3 25-60 180	180	90	72	45	36	92	128	G 1 1/2	2.0

Technical data

System pressure	Max. 1.0 MPa (10 bar)	Enclosure class	IP44 (non-condensing)
Minimum inlet pressure	0.05 MPa (0.50 bar) at 95 °C liquid temperature	Motor protection	No external protection needed
Liquid temperature	+2 °C to +110 °C (TF110)	Approval and marking	VDE, CE

### UPM3 15-50 130, 25-50 130, 25-50 180

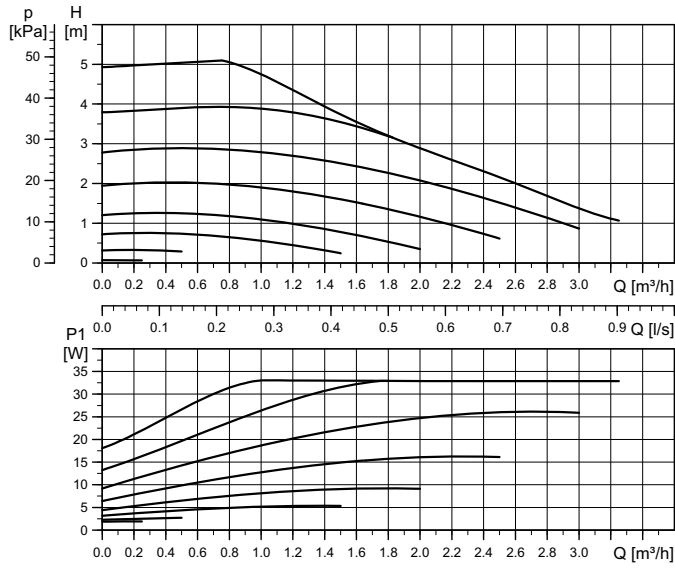

High efficiency

Ready for Ecodesign 2015

EEI ≤ 0.20 Part 3

P<sub>L,avg</sub> ≤ 16 W

TM06 0577 0814

Performance curve

**Electrical data, 1 x 230 V, 50 Hz**

Speed	P <sub>1</sub> [W]	I <sub>1/1</sub> [A]
Min.	2	0.04
Max.	33	0.36

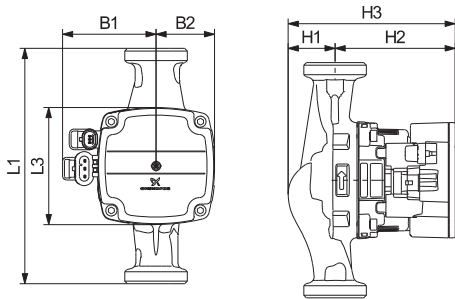

TM06 0697 0814



TM06 0785 0914

Dimensions

Control box position

Pump type	Dimensions [mm]							Connections	Weight [kg]
	L1	L3	B1	B2	H1	H2	H3		
UPM3 15-50 130	130	90	72	45	36	92	128	G 1	1.8
UPM3 25-50 130	130	90	72	45	36	92	128	G 1 1/2	1.9
UPM3 25-50 180	180	90	72	45	36	92	128	G 1 1/2	2.0

**Technical data**

<b>System pressure</b>	Max. 1.0 MPa (10 bar)	<b>Enclosure class</b>	IP44 (non-condensing)
<b>Minimum inlet pressure</b>	0.05 MPa (0.50 bar) at 95 °C liquid temperature	<b>Motor protection</b>	No external protection needed
<b>Liquid temperature</b>	+2 °C to +110 °C (TF110)	<b>Approval and marking</b>	VDE, CE

UPM3 15-40 130, 25-40 130, 25-40 180

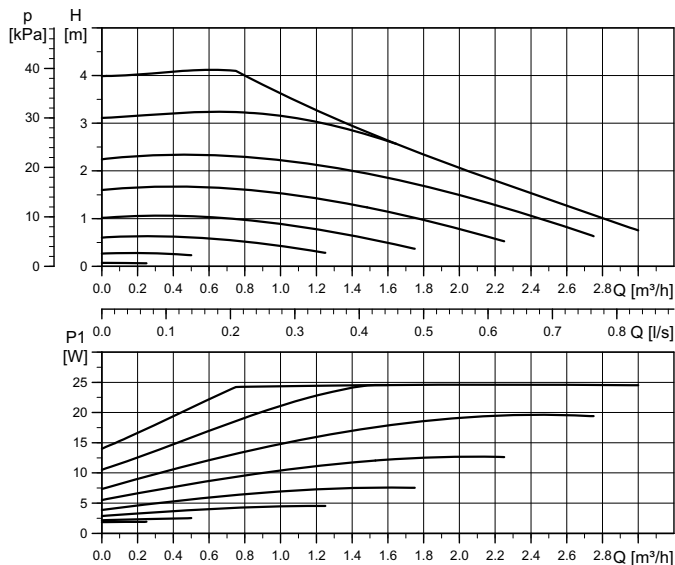

High efficiency

Ready for Ecodesign 2015

EEI ≤ 0.20 Part 3

P<sub>L,avg</sub> ≤ 12 W

TM06 0576 0814

Performance curve

Electrical data, 1 x 230 V, 50 Hz

Speed	P <sub>1</sub> [W]	I <sub>1/1</sub> [A]
Min.	2	0.04
Max.	25	0.30

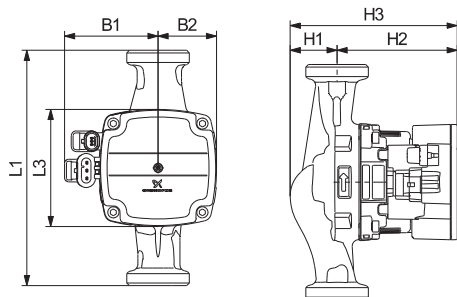

TM06 0697 0814



TM06 0785 0914

Dimensions

Control box position

Pump type	Dimensions [mm]							Connections	Weight [kg]
	L1	L3	B1	B2	H1	H2	H3		
UPM3 15-40 130	130	90	72	45	36	92	128	G 1	1.8
UPM3 25-40 130	130	90	72	45	36	92	128	G 1 1/2	1.9
UPM3 25-40 180	180	90	72	45	36	92	128	G 1 1/2	2.0

Technical data

System pressure	Max. 1.0 MPa (10 bar)	Enclosure class	IP44 (non-condensing)
Minimum inlet pressure	0.05 MPa (0.50 bar) at 95 °C liquid temperature	Motor protection	No external protection needed
Liquid temperature	+2 °C to +110 °C (TF110)	Approval and marking	VDE, CE

### UPM3 FLEX AC 15-70 130, 25-70 130, 25-70 180

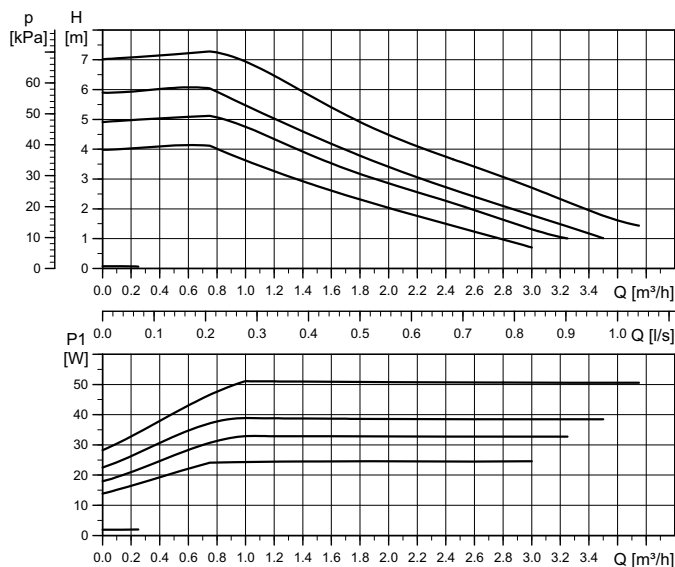

High efficiency

Ready for Ecodesign 2015

EEI ≤ 0.20 Part 3  
 $P_{L,avg} \leq 23 \text{ W}$

TM06 0584 0814

Performance curve

**Electrical data, 1 x 230 V, 50 Hz**

Speed	$P_1$ [W]	$I_{1/1}$ [A]
Min.	2	0.04
Max.	52	0.52

**Note:** For PWM speed curves see data sheet UPM3 15-70 130, 25-70 130, 25-70 180.

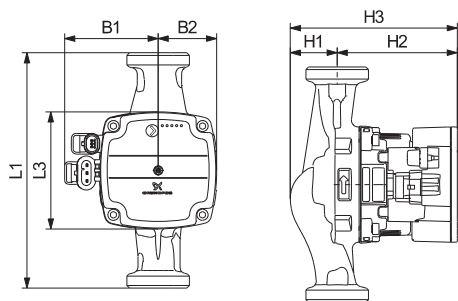

TM05 8555 0114



TM06 0765 0914

Dimensions

Control box position

Pump type	Dimensions [mm]							Connections	Weight [kg]
	L1	L3	B1	B2	H1	H2	H3		
UPM3 FLEX AC 15-70 130	130	90	72	45	36	92	128	G 1	1.8
UPM3 FLEX AC 15-70 130	130	90	72	45	36	92	128	G 1 1/2	1.9
UPM3 FLEX AC 15-70 180	180	90	72	45	36	92	128	G 1 1/2	2.0

**Technical data**

<b>System pressure</b>	Max. 1.0 MPa (10 bar)	<b>Enclosure class</b>	IP44 (non-condensing)
<b>Minimum inlet pressure</b>	0.05 MPa (0.50 bar) at 95 °C liquid temperature	<b>Motor protection</b>	No external protection needed
<b>Liquid temperature</b>	+2 °C to +110 °C (TF110)	<b>Approval and marking</b>	VDE, CE

UPM3 FLEX AS 15-70 130, 25-70 130, 25-70 180

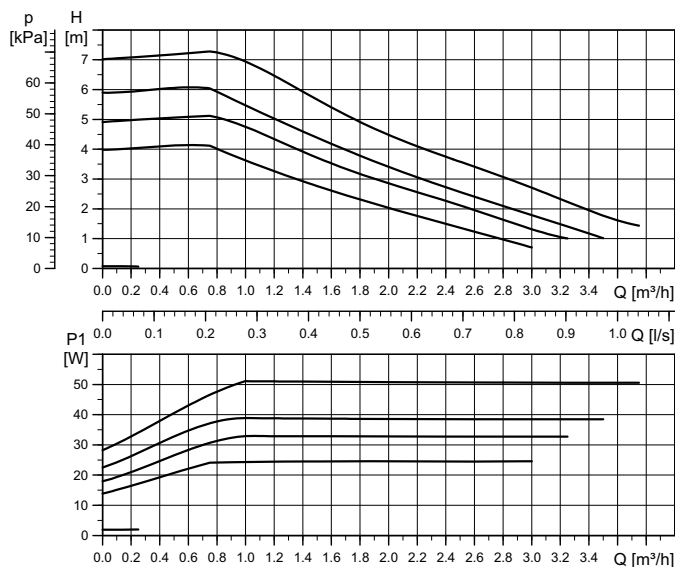

High efficiency

Ready for Ecodesign 2015

EEI ≤ 0.20 Part 3

P<sub>L,avg</sub> ≤ 23 W

TM06 0584 0814

UPM3 FLEX AS 15-70 130, 25-70 130, 25-70 180

Performance curve

Electrical data, 1 x 230 V, 50 Hz		
Speed	P <sub>1</sub> [W]	I <sub>1/I</sub> [A]
Min.	2	0.04
Max.	52	0.52

Note: For PWM speed curves see data sheet UPM3 15-70 130, 25-70 130, 25-70 180.

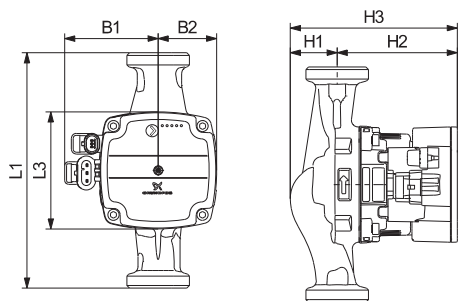

TM05 8555 0114



TM06 0765 0914

Dimensions

Control box position

Pump type	Dimensions [mm]							Connections	Weight [kg]
	L1	L3	B1	B2	H1	H2	H3		
UPM3 FLEX AC 15-70 130	130	90	72	45	36	92	128	G 1	1.8
UPM3 FLEX AC 15-70 130	130	90	72	45	36	92	128	G 1 1/2	1.9
UPM3 FLEX AC 15-70 180	180	90	72	45	36	92	128	G 1 1/2	2.0

Technical data

System pressure	Max. 1.0 MPa (10 bar)	Enclosure class	IP44 (non-condensing)
Minimum inlet pressure	0.05 MPa (0.50 bar) at 95 °C liquid temperature	Motor protection	No external protection needed
Liquid temperature	+2 °C to +110 °C (TF110)	Approval and marking	VDE, CE

### UPM3 AUTO L 15-70 130, 25-70 130, 25-70 180

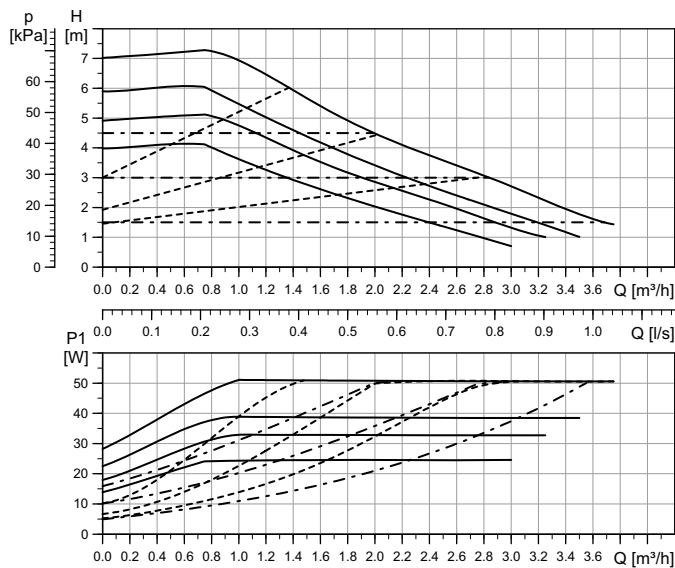

High efficiency

Ready for Ecodesign 2015

EEI ≤ 0.20 Part 2

P<sub>L,avg</sub> ≤ 25 W

Performance curve

Line type	Description
—————	Constant Curve
- - - - -	Proportional Pressure
- · - · -	Constant Pressure

Electrical data, 1 x 230 V, 50 Hz

Speed	P <sub>1</sub> [W]	I <sub>1/1</sub> [A]
Min.	5	0.07
Max.	52	0.52

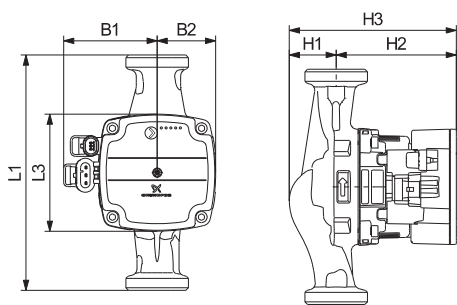

TM05 8555 0114



TM06 0785 0914

Dimensions

Control box position

Pump type	Dimensions [mm]							Connections	Weight [kg]
	L1	L3	B1	B2	H1	H2	H3		
UPM3 AUTO L 15-70 130	130	90	72	45	36	92	128	G 1	1.8
UPM3 AUTO L 25-70 130	130	90	72	45	36	92	128	G 1 1/2	1.9
UPM3 AUTO L 25-70 180	180	90	72	45	36	92	128	G 1 1/2	2.0

Technical data

System pressure	Max. 1.0 MPa (10 bar)	Enclosure class	IP44 (non-condensing)
Minimum inlet pressure	0.05 MPa (0.50 bar) at 95 °C liquid temperature	Motor protection	No external protection needed
Liquid temperature	+2 °C to +110 °C (TF110)	Approval and marking	VDE, CE

UPM3 AUTO L 15-50 130, 25-50 130, 25-50 180

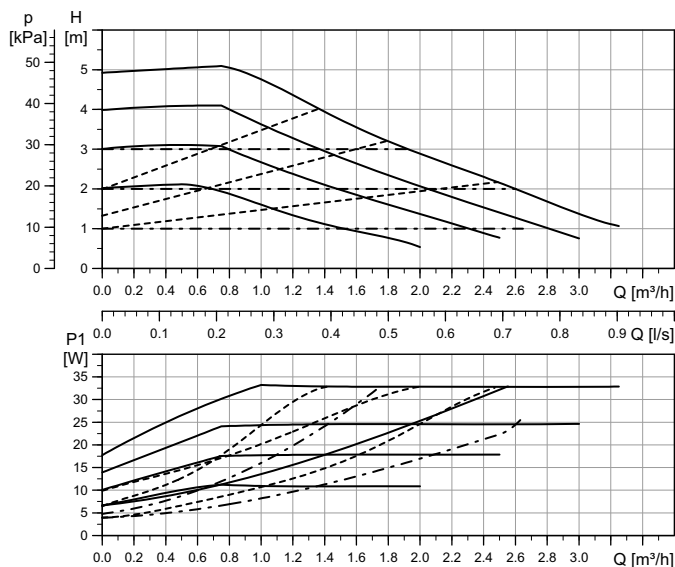

High efficiency

Ready for Ecodesign 2015

EEI ≤ 0.20 Part 2

P<sub>L,avg</sub> ≤ 16 W

TM06 0581 0814

UPM3 AUTO L 15-50 130, 25-50 130, 25-50 180

Performance curve

Line type	Description
—————	Constant Curve
-----	Proportional Pressure
- · - · - · -	Constant Pressure

Electrical data, 1 x 230 V, 50 Hz

Speed	P <sub>1</sub> [W]	I <sub>1/1</sub> [A]
Min.	4	0.06
Max.	33	0.36

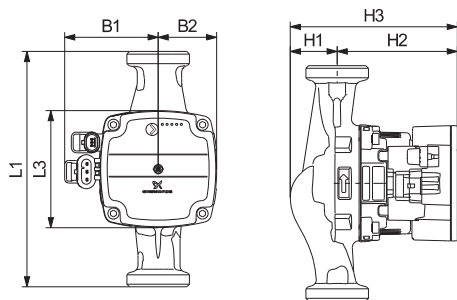

TM05 8555 0114



TM06 0785 0914

Dimensions

Control box position

Pump type	Dimensions [mm]							Connections	Weight [kg]
	L1	L3	B1	B2	H1	H2	H3		
UPM3 AUTO L 15-50 130	130	90	72	45	36	92	128	G 1	1.8
UPM3 AUTO L 25-50 130	130	90	72	45	36	92	128	G 1 1/2	1.9
UPM3 AUTO L 25-50 180	180	90	72	45	36	92	128	G 1 1/2	2.0

Technical data

System pressure	Max. 1.0 MPa (10 bar)	Enclosure class	IP44 (non-condensing)
Minimum inlet pressure	0.05 MPa (0.50 bar) at 95 °C liquid temperature	Motor protection	No external protection needed
Liquid temperature	+2 °C to +110 °C (TF110)	Approval and marking	VDE, CE

## UPM3 AUTO 15-70 130, 25-70 130, 25-70 180

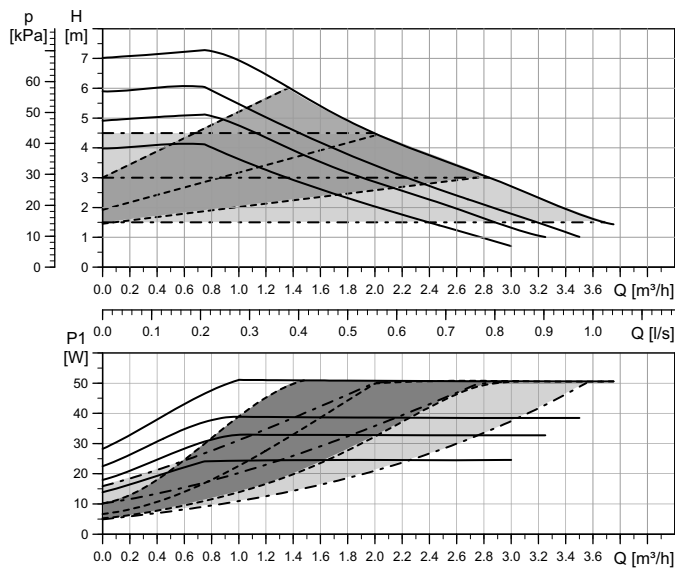

High efficiency

Ready for Ecodesign 2015

EEI ≤ 0.20 Part 2

$P_{L,avg} \leq 25 \text{ W}$

TM06 1179 1814

Performance curve

Line type	Description
—————	Constant Curve
-----	Proportional Pressure
- - - - -	Constant Pressure

### Electrical data, 1 x 230 V, 50 Hz

Speed	$P_1$ [W]	$I_{1/1}$ [A]
Min.	5	0.07
Max.	52	0.52

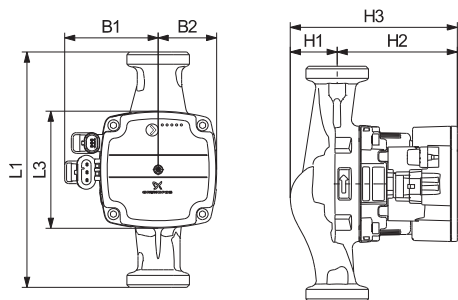

TM05 8555 0114



TM06 0785 0914

Dimensions

Control box position

Pump type	Dimensions [mm]							Connections	Weight [kg]
	L1	L3	B1	B2	H1	H2	H3		
UPM3 AUTO 15-70 130	130	90	72	45	36	92	128	G 1	1.8
UPM3 AUTO 25-70 130	130	90	72	45	36	92	128	G 1 1/2	1.9
UPM3 AUTO 25-70 180	180	90	72	45	36	92	128	G 1 1/2	2.0

### Technical data

<b>System pressure</b>	Max. 1.0 MPa (10 bar)	<b>Enclosure class</b>	IP44 (non-condensing)
<b>Minimum inlet pressure</b>	0.05 MPa (0.50 bar) at 95 °C liquid temperature	<b>Motor protection</b>	No external protection needed
<b>Liquid temperature</b>	+2 °C to +110 °C (TF110)	<b>Approval and marking</b>	VDE, CE



UPM3 AUTO 15-50 130, 25-50 130, 25-50 180

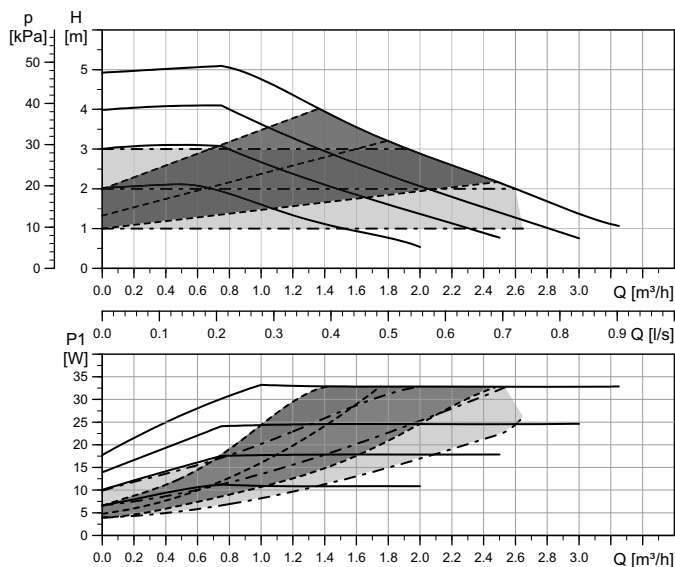

High efficiency

Ready for Ecodesign 2015

EEI ≤ 0.20 Part 2

P<sub>L,avg</sub> ≤ 16 W

TM06 1180 1814

UPM3 AUTO 15-50 130, 25-50 130, 25-50 180

Performance curve

Line type	Description
—————	Constant Curve
-----	Proportional Pressure
- - - - -	Constant Pressure

Electrical data, 1 x 230 V, 50 Hz

Speed	P <sub>1</sub> [W]	I <sub>1/1</sub> [A]
Min.	4	0.06
Max.	33	0.36

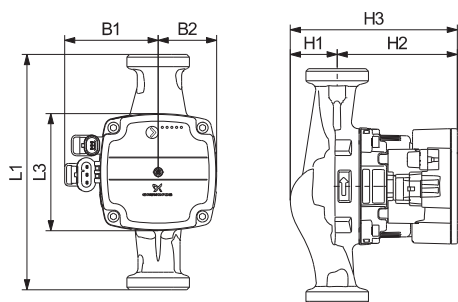

TM05 8555 0114



TM06 0785 0914

Dimensions

Control box position

Pump type	Dimensions [mm]							Connections	Weight [kg]
	L1	L3	B1	B2	H1	H2	H3		
UPM3 AUTO 15-50 130	130	90	72	45	36	92	128	G 1	1.8
UPM3 AUTO 25-50 130	130	90	72	45	36	92	128	G 1 1/2	1.9
UPM3 AUTO 25-50 180	180	90	72	45	36	92	128	G 1 1/2	2.0

Technical data

System pressure	Max. 1.0 MPa (10 bar)	Enclosure class	IP44 (non-condensing)
Minimum inlet pressure	0.05 MPa (0.50 bar) at 95 °C liquid temperature	Motor protection	No external protection needed
Liquid temperature	+2 °C to +110 °C (TF110)	Approval and marking	VDE, CE

### UPM3 HYBRID 15-70 130, 25-70 130, 25-70 180

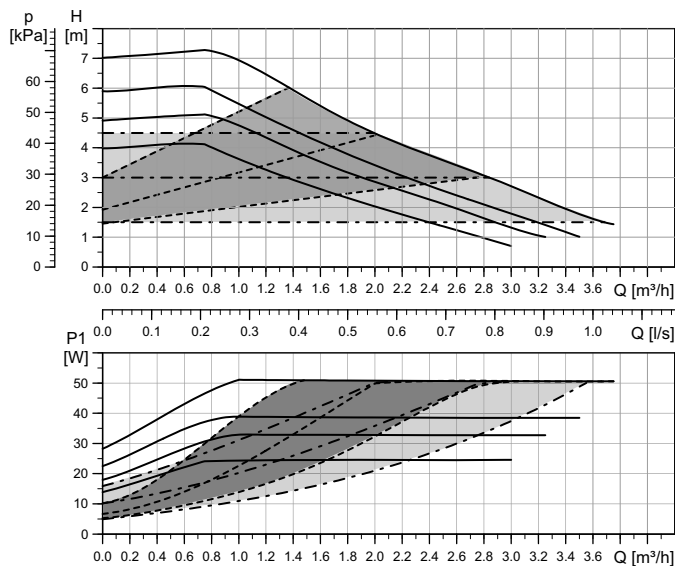

High efficiency

Ready for Ecodesign 2015

EEI ≤ 0.20 Part 3

$P_{L,avg} \leq 25$  W

TM06 1179 1814

Performance curve

Line type	Description
—————	Constant Curve
-----	Proportional Pressure
- - - - -	Constant Pressure

Electrical data, 1 x 230 V, 50 Hz

Speed	$P_1$ [W]	$I_{1/1}$ [A]
Min.	2	0.04
Max.	53	0.52

Note: For PWM speed curves see data sheet UPM3 15-70 130, 25-70 130, 25-70 180.

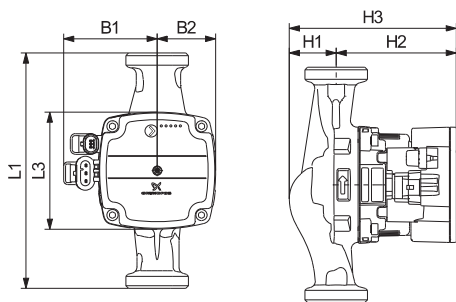

TM05 8555 0114



TM06 0785 0914

Dimensions

Control box position

Pump type	Dimensions [mm]							Connections	Weight [kg]
	L1	L3	B1	B2	H1	H2	H3		
UPM3 HYBRID 15-70 130	130	90	72	45	36	92	128	G 1	1.8
UPM3 HYBRID 25-70 130	130	90	72	45	36	92	128	G 1 1/2	1.9
UPM3 HYBRID 25-70 180	180	90	72	45	36	92	128	G 1 1/2	2.0

Technical data

System pressure	Max. 1.0 MPa (10 bar)	Enclosure class	IP44 (non-condensing)
Minimum inlet pressure	0.05 MPa (0.50 bar) at 95 °C liquid temperature	Motor protection	No external protection needed
Liquid temperature	+2 °C to +110 °C (TF110)	Approval and marking	VDE, CE

UPM3 HYBRID 15-50 130, 25-50 130, 25-50 180

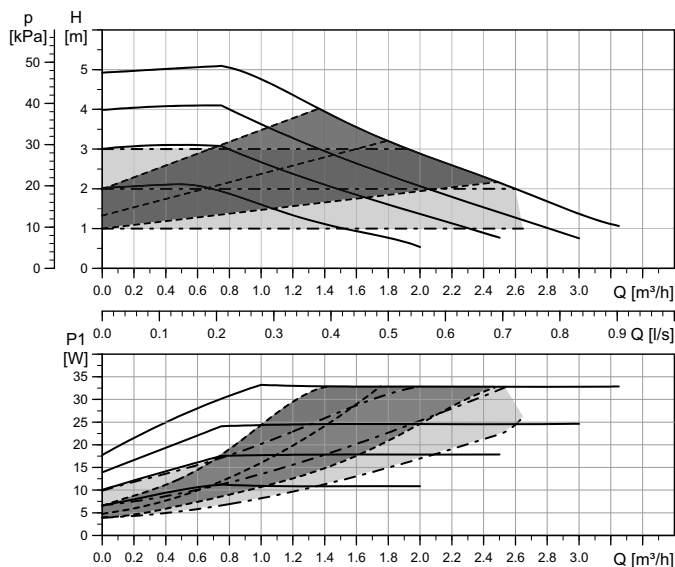

High efficiency

Ready for Ecodesign 2015

EEI ≤ 0.20 Part 3

P<sub>L,avg</sub> ≤ 16 W

TM06 1180 1814

UPM3 HYBRID 15-50 130, 25-50 130, 25-50 180

Performance curve

Line type	Description
—————	Constant Curve
-----	Proportional Pressure
- - - - -	Constant Pressure

Electrical data, 1 x 230 V, 50 Hz

Speed	P <sub>1</sub> [W]	I <sub>1/1</sub> [A]
Min.	2	0.04
Max.	34	0.37

Note: For PWM speed curves see data sheet UPM3 15-70 130, 25-70 130, 25-70 180.

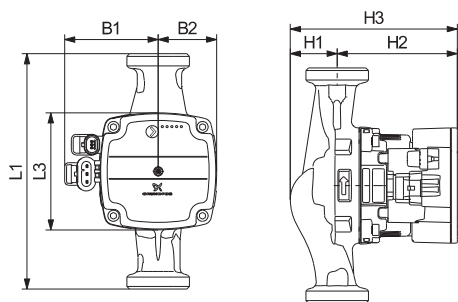

TM05 8555 0114



TM06 0785 0914

Dimensions



Control box position

Pump type	Dimensions [mm]							Connections	Weight [kg]
	L1	L3	B1	B2	H1	H2	H3		
UPM3 HYBRID 15-50 130	130	90	72	45	36	92	128	G 1	1.8
UPM3 HYBRID 25-50 130	130	90	72	45	36	92	128	G 1 1/2	1.9
UPM3 HYBRID 25-50 180	180	90	72	45	36	92	128	G 1 1/2	2.0

Technical data

System pressure	Max. 1.0 MPa (10 bar)	Enclosure class	IP44 (non-condensing)
Minimum inlet pressure	0.05 MPa (0.50 bar) at 95 °C liquid temperature	Motor protection	No external protection needed
Liquid temperature	+2 °C to +110 °C (TF110)	Approval and marking	VDE, CE

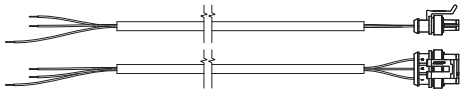
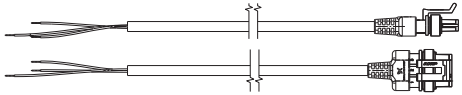
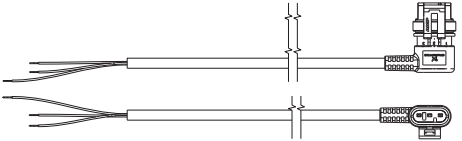
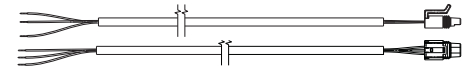
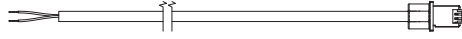
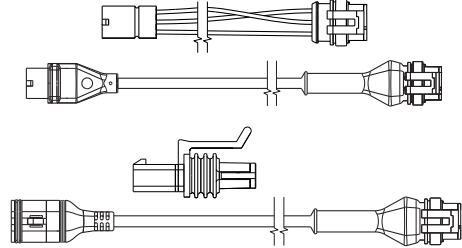
## 14. Accessories

Picture	Product description	Length [mm]	Product number
<b>Power supply Superseal</b>			
	Power supply cable Superseal	1,000	98460260
	Power supply cable Superseal	2,000	98373382
	Power supply cable Superseal	4,000	98460271
<b>Power supply Superseal overmoulded</b>			
	Power supply Superseal overmoulded	1,000	98460258
	Power supply Superseal overmoulded	2,000	98373384
	Power supply Superseal overmoulded	4,000	98460259
<b>Power supply Superseal overmoulded angled</b>			
	Power supply Superseal overmoulded angled 90 °	1,000	98616020
	Power supply Superseal overmoulded angled 90 °	2,000	98616051
<b>Signal cable Mini Superseal</b>			
	Signal cable, Mini Superseal	1,000	98460256
	Signal cable, Mini Superseal	2,000	98347385
<b>Signal cable FCI</b>			
	Signal cable, FCI, 2 wire - non return signal	1,000	98386202
	Signal cable, FCI, 3 wire - with return signal	1,000	96645398
	Signal cable, FCI, 2 wire - non return signal	2,000	97698929
	Signal cable, FCI, 3 wire - with return signal	2,000	97940991
<b>Power cable adapters</b>			
	Superseal Molex cable adapter	50	98556867
	Superseal Molex cable adapter overmoulded	150	98614629
	Superseal Molex adapter	-	98615161
	Superseal Volex cable adapter overmoulded	150	98614444
<b>Signal blind plugs</b>			
	Blind plug, FCI	-	97823485
	Blind plug, Mini Superseal	-	98451691

## Gaskets

Description	Product number
Gasket 1" (D29,5/D21x2)	504023
Gasket 1 1/2" (D44/D32x2), rubber	520046

## Insulation kits

Insulation kits for warm water applications are available on request. Insulation kits for warm water applications contain two insulation shells. The thickness of the insulation shells corresponds to the nominal diameter of the pump. The insulation kit is tailor-made for the individual pump type and encloses the entire pump housing. Both insulation shells are easy to fit around the pump.

Diffusion-tight insulation shells for cold water applications are not available.

## Quick guides

Quick guides for different UPM3 HYBRID variants are available on request.

## 15. Approvals and certificates

### EC declaration of conformity

We, Grundfos, declare under our sole responsibility that the products **GFNJB (UPM variants with user interface)** and **GFNJC (other UPM3 variants)**, to which this declaration relates, are in conformity with these Council directives on the approximation of the laws of the EC member states:

#### Low Voltage Directive (2006/95/EC)

Standards used:

- EN 60335-1:2012/AC:2014
- EN 60335-2-51:2003/A1:2008/A2:2012

#### EMC Directive (2004/108/EC)

Standards used:

- EN 55014-1:2006/A1:2009
- EN 55014-2:1997/A1:2001/A2:2008

#### Ecodesign Directive (2009/125/EC)

Commission Regulation (EC) No 641/2009

Commission Regulation (EC) No 622/20012

Standards used:

- EN 16297-1:2012
- EN 16297-2:2012
- EN 16297-3:2012

#### Warning

The use of this product requires experience with and knowledge of the product. Persons with reduced physical, sensory or mental capabilities must not use this product, unless they are under supervision or have been instructed in the use of the product by a person responsible for their safety. Children must not use or play with this product.

Bjerringbro, 21<sup>st</sup> of February 2014

Preben Jakobsen  
 Technical Manager - HVAC OEM  
 GRUNDFOS Holding A/S  
 Poul Due Jensens Vej 7  
 8850 Bjerringbro, Denmark

Person authorised to compile technical file and empowered to sign the EC declaration of conformity.

### VDE certificate

These pumps are certified by VDE.

Product code: GFNJB or GFNJC

VDE certificate No. 40039416

This Marks Approval forms the basis of the CE declaration of conformity and the CE marking by the manufacturer or his agent and proves the conformity with the essential safety requirements of the EC Low Voltage Directive (2006/95/EC) including amendments.

## REACH compliancy - Chemical Management - Grundfos Focus List

At Grundfos, we run our business in a responsible and ever more sustainable way. We are committed to creating products and solutions that help our customers and the surrounding world conserve natural resources and reduce climate impacts. This is part of the Grundfos Values, as well as in accordance with the Grundfos Sustainability Strategy, which has the scope of reducing our chemical footprint and developing new sustainable products and solutions.

In order to give our suppliers, contractors and other relevant stakeholder world wide a tool to help comply with this, we have devised the Grundfos Focus List, which bans or restricts the use of chemical substances in Grundfos products, production processes and at Grundfos facilities.

This in turn means that all our various business partners at all times are obliged to follow the Grundfos Focus List and never deliver any products, processes or services containing any of the listed chemical substances.

The list has been developed on the basis of European chemical legislation such as the REACH regulation, RoHS, Battery, Packaging, ODS (Ozone Depleting Substances) and POPs (Persistent Organic Pollutants) directives.

Furthermore, we ban the Substances of Very High Concern (SVHC) from the REACH Candidate List ([www.echa.europa.eu/web/guest/candidate-list-table](http://www.echa.europa.eu/web/guest/candidate-list-table)).

Should a product contain SVHC from the Candidate List above 0.1 percent, this must be declared and a plan to phase out the SVHC within a year must be sent to Grundfos.

In situations, where local legislation is stricter than European chemical legislation, these demands will overrule the claims of the Focus List.

The valid Focus list is at all times available at [www.grundfos.com/focus-list](http://www.grundfos.com/focus-list). However, users of the list are responsible for taking legal updates of the listed regulations into account.

With kind regards,



Torben Brændgaard

Group Environment Manager

## Declaration concerning GRUNDFOS' compliance with RoHS and WEEE directive

GRUNDFOS Holding A/S and its subsidiaries accept their responsibilities and are committed not to use hazardous substances in their products. Grundfos products are not as of today in general covered by the WEEE- and RoHS-directives.

In regards to the RoHS directive (2002/95/EC) amended by directive (2011/65/EC) on the restriction of the use of certain hazardous substances in electrical and electronic equipment (EEE) latest in 2019 all EEE will as a starting point be affected.

However, Grundfos is now in complete voluntary RoHS-compliance concerning the non-use of the certain hazardous substance in GRUNDFOS products - see section about "Chemical Management - Grundfos Focus List".

In regards to the WEEE-directive (2002/96/EC) amended by directive (2012/19/EC) and its impact on pumps, Grundfos recommends reading the Europump position paper of 16 December 2005 which can be found on <http://europump.net/publications/position-papers>.

From 2018, all EEE will be within the scope of the WEEE-directive II, however several of the exemptions apply to many of Grundfos' products and Grundfos will be working on the implementation of this towards 2018.

For detailed information on recycling, please see [www.grundfos.com/product-recycling](http://www.grundfos.com/product-recycling).

98644852 0314

ECM: 1120472