

ESBE SYSTEM UNITS RETURN TEMPERATURE

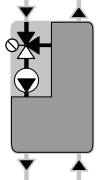
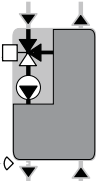
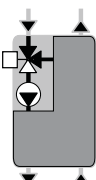
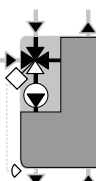

PAGE	CONTENT
1	Series and Function • General/Safety
2	Hydraulic Installation • Electric Installation • Commissioning
3	Circulation pump operation mode WILO
4	WILO Faults, Causes and Remedies
5	Circulation pump operation mode GRUNDFOS
6	How to use the information leaflet • Maintenance • Spare parts

SERIES	FUNCTION
ESBE GST100	 <p>Fixed temperature With a VTC Load valve ready and mounted on the Return Temperature Unit.</p>
ESBE GSC110	 <p>Mixing function With Controller CRA ready and mounted on the Return Temperature Unit.</p>
ESBE GSA100	 <p>Mixing function With Actuator ARA ready and mounted on the Return Temperature Unit.</p>
ESBE GSC120	 <p>Bivalent function With Controller CRA ready and mounted on the Return Temperature Unit.</p>

1 i GENERAL/SAFETY

RoHS
LVD 73/23/EEC
EMC 89/336/EEC
PED
Max. operating pressure: PN 6

This instruction manual is an essential component of the product. Read the instructions and the warnings carefully as they contain important information about a safe installation, usage and maintenance.

This product can be used only for the circulation of water and water/glycol in heating installations.

i INSTALLATION EXAMPLE

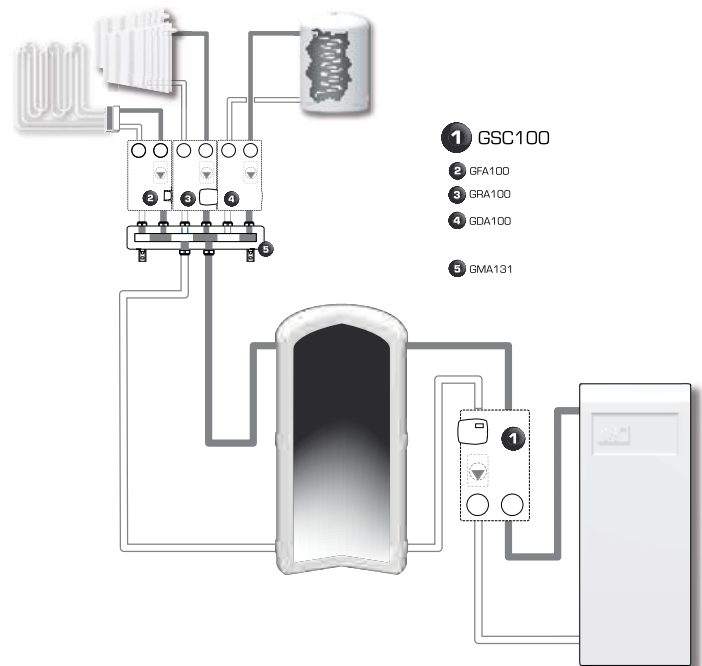

All piping schematics are general representations

The producer won't be responsible for damages caused by wrong usage or unrespect of the instructions given in this manual.

The mounting of the unit must be performed by a qualified professional and in compliance with local/regional laws. This manual refers to standard products. Different versions or functions are available.

At mounting - pay attention and follow common practice and general safety norms for the use of machineries, pressurized equipment and at high temperatures.

For electrical components integrated into this product copies of corresponding CE declaration are part of this instruction.

We reserve the right to modify or improve the product, its technical data and literature at any time and without notice.



Actuator/Controller



Circulation pump
Grundfos

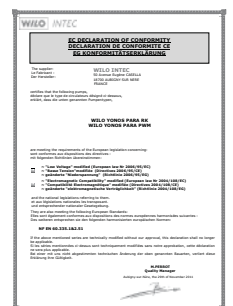

Circulation pump
Wilo

2 HYDRAULIC INSTALLATION

SINGULAR INSTALLATION ON THE WALL

Install the appliance on a solid wall.

1. Choose the correct position for the piping and drilling by usage of the Mounting template supplied with the package. Drill the holes in the wall for your installation purposes. Take care not to damage any electrical wiring or existing piping.

2. Detach parts of the Return Temperature Unit's insulation shell.

The actuator/controller might be dismantled from the valve to give more space for the installation tools. Do not change the shaft position of the valve.

3. Mount the Return Temperature Unit on the wall with the supplied screws and plugs. Ensure that the pipes are completely in line and lock them firmly. *Please note that to achieve best performance there should be no tilt at all.

⚠ WARNING! For all installations, verify that the plugs are suitable for the kind of wall chosen. Otherwise replace them with a special model. To value the suitability of the plugs please consider the structure of the wall, all the units connected and the weight of the water.

4. Connect the pipings.

⚠ WARNING! Equipment might be damaged when incorrect usage of tools.

5. Remount the insulation shell parts (and actuator/controller).

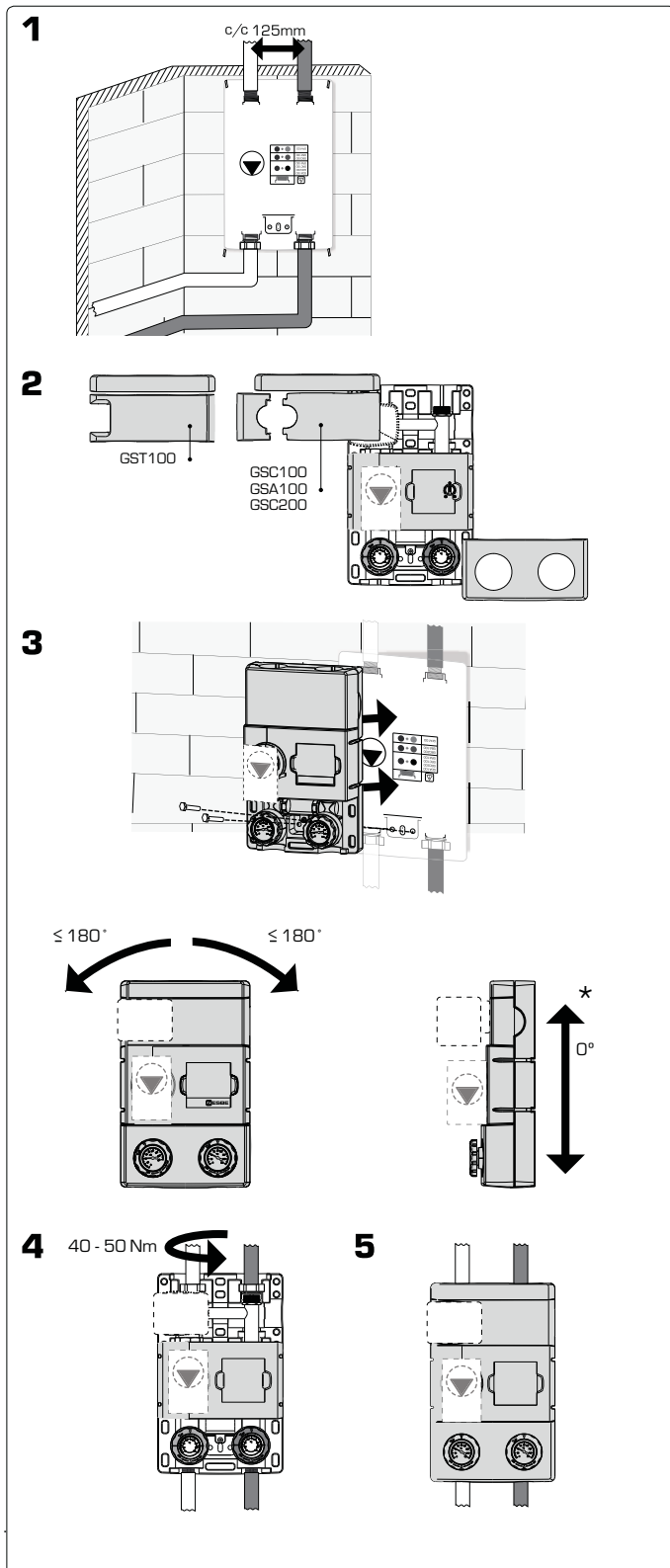

FEED OF OPEN SYSTEMS

When installing in the feed of open systems, the safety supply must branch off upstream of the Return Temperature Unit (EN 12828).

3 ELECTRIC INSTALLATION

Electric connection of the Return Temperature Unit depends both on the circulation pump, actuator and /or controller.

CIRCULATION PUMP 230 VAC, 50HZ:

The circulation pump should be preceded by a multi-pole contact breaker in the fixed installation. Earth-connection should not be broken.

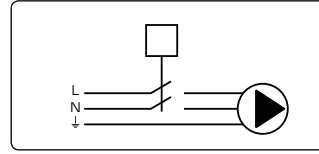

You find more information about the circulation pump on www.esbe.eu.

ACTUATOR:

Actuators supplied with 230 VAC should be preceded by a multipole contact breaker in the fixed installation.

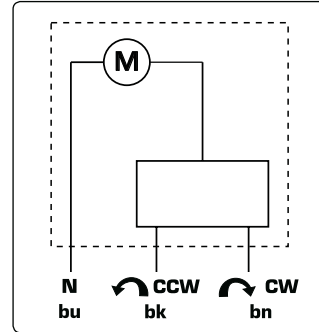

You find more information about the actuator on www.esbe.eu.

CONTROLLER:

For more information regarding electric connection and parameters setting, read CRA instruction manual enclosed.

IF USING LARGER SYSTEMS/CENTRAL REGULATING

Read each product's instruction manual.

4 COMMISSIONING RETURN TEMPERATURE UNIT

⚠ WARNING! Before any intervention disconnect the electric mains through the external mounted switch and depressurise!

⚠ WARNING! Depending on the operating status of the circulation pump or system (fluid temperature), the entire Return Temperature Unit can become very hot.

Both primary and secondary loops have to be washed in order to remove any possible mounting residuals.

Check that all connections are fully tightened: it's important to check all connections before filling the system in order to avoid leakages or sprays which may be dangerous for the electric components. Open all shut-off valves and fill the primary and secondary loop following the instructions for the tank, boiler etc. During the filling phase recheck that all connections are tightened.

FILLING AND VENTING

Fill the buffer tank and the primary loop with an appropriated liquid, according to the system instructions, respecting the limits of the components used.

While filling the device, open any vents situated in the circuit. Watch the system until it reaches its correct operation condition. If pressure is not enough, adjust the pressure by repeating the above procedure.

To avoid problems with cavitation, fill up the system to get sufficient pressure head on the suction side of the circulation pump. The minimum pressure needed depends on the temperature of the fluid. Recommended min pressure head at fluid temperatures 50/95/110°C is 0,5/4,5/11 m respectively.

Only for Wilo: Start the venting function by setting the operation knob of the circulation pump in venting function described in chapter 5.

To make the filling and venting of the system easier it's possible to force the check valve on the return side of the unit, to an open position (default), see Fig. 1 .

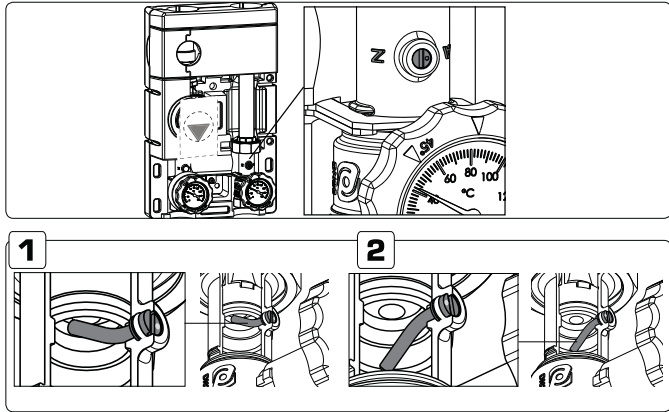

After a complete filling and venting cycle, turn the screw on the check valve back to its normal operating position, picture 2 and set the circulation pump operation to recommended position. See chapter 5 Wilo and chapter 6 Grundfos.

COMMISSIONING ACTUATOR:

During commissioning it might be useful to turn the valve manually by pulling the knob, picture A. Reset to operation mode by pushing and adjusting the knob back, picture B.

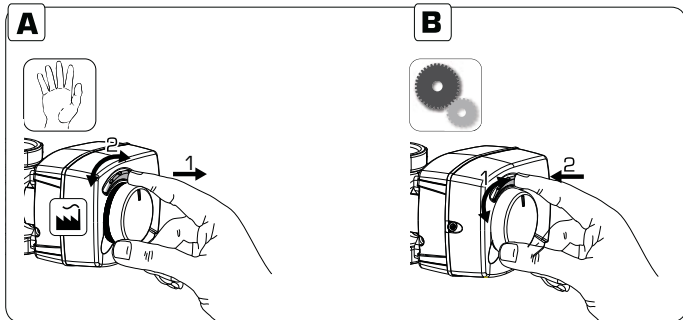

COMMISSIONING CONTROLLER:

For more information regarding commissioning, read CRA instruction manuals enclosed.

COMMISSIONING IF USING LARGER SYSTEMS/CENTRAL REGULATING
Please read each product's instruction manual.

COMMISSIONING FIXED TEMPERATURE OPERATION

To set the mixed water temperature, see recommendations in the table below. All temperature settings must be measured at suitable location with a thermometer to have the correct mixing temperature of the valve.

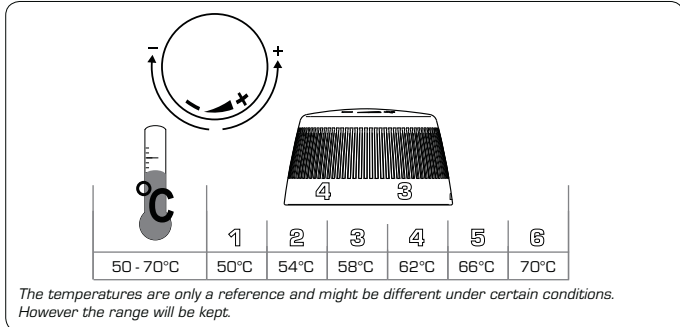

The Return Temperature Units Series GST130 are delivered with three wax elements: 50/55/60°C. Factory assembly: 55°C.

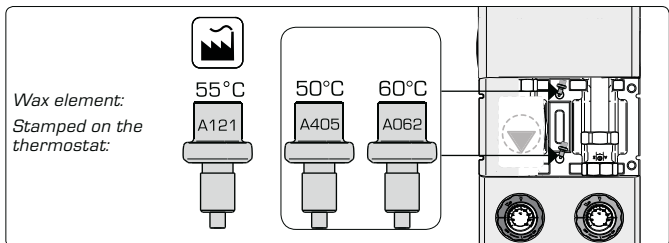

If change is required you find the 55°C and 60°C wax element inside the insulaiton shell. follow the instructions as described in picture 1-8.

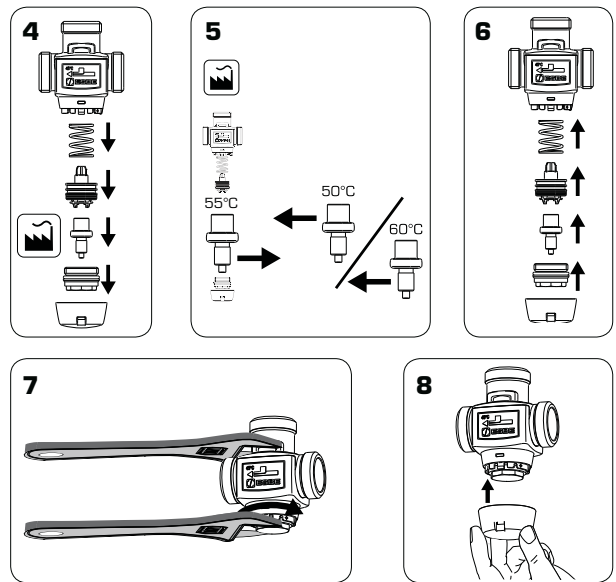
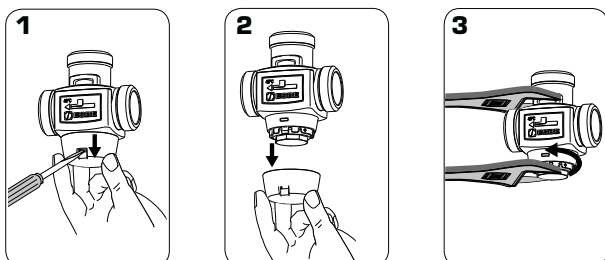

5 WILO - CIRCULATION PUMP

OPERATION MODE

All functions can be set, activated or deactivated by using the operating knob. The circulation pump is equipped with a LED indicator in order to display the circulation pump operating status. More information in table "Faults, causes and remedies" page 4

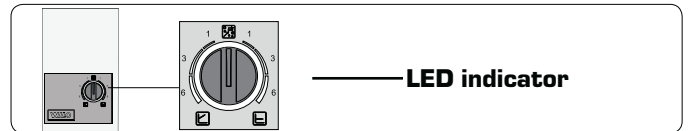

VARIABLE DIFFERENTIAL PRESSURE (ΔP-V) :

The differential-pressure set point H is increased linearly over the permitted volume flow range between 1/2 H and H.

CONSTANT DIFFERENTIAL PRESSURE (ΔP-C):

The differential-pressure set point H is kept constant over the permitted volume flow range at the selected differential-pressure set point up to the maximum circulation pump curve.

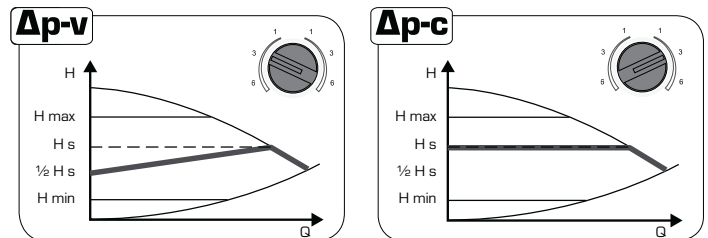

FILLING AND VENTING FUNCTION

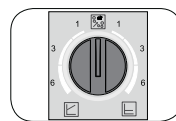

Fill and vent the system correctly. If direct venting of the rotor chamber is required, the venting function can be started manually. By turning the operating knob to the symbol for venting in the middle position, the venting function is activated after 3 seconds.

The venting function lasts 10 minutes and is indicated with quick green LED blinking. Noises may be heard when the venting function is running. The process can be stopped if desired by turning the knob. After 10 minutes, the circulation pump stops and goes automatically in Δp-c max mode.

WARNING! Dont forget to turn the knob back to recommended setting!

NOTE: The venting function removes accumulated air from the rotor chamber of the circulation pump. The venting function of the circulation pump does not necessarily vent the heating system.

During automatic venting function (10min) the circulation pump alternates between high and low speeds in order for air bubbles to be released from the rotor and transported to the venting valve of the installation.

AUTOMATIC AIR VENTING ROUTINE

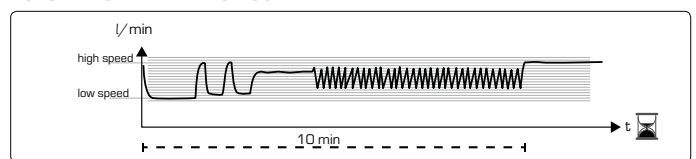



WILO - FAULTS, CAUSES AND REMEDIES

Faults	Meaning	Diagnostic	Cause	Remedy
Return Temperature Unit not operating	Overheating	Pump not running, led is off. Actuator/Controller not running.	No power supply	Check connections
Return Temperature Unit not operating	Overheating	Pump is running, led is on. Actuator/Controller is running.	Shut off valves are closed	Open all shut off valves
Return Temperature Unit not operating properly	Low performance	Noise from the system. Pump and Actuator/Controller is running	Air in the system blocks the circulation.	Remove air from the system by filling and venting, see chapter 4.
To high Pressure Differential	Poor energy performance of the pump	Noise from system. Low temperature difference over boiler	To high circulation pump speed	Decrease speed of circulation pump, see chapter 5.
LED lights green	Circulation pump in operation	Circulation pump runs according it's setting	Normal operation	
LED blinks quick green	Circulation pump in air venting mode	Circulation pump runs during 10 min in air venting function. Afterwards the desired mode must be selected.	Normal operation	
LED blinks red/green	Circulation pump in function but stopped	Circulation pump restarts by itself after the fault has been dealt with.	1. Under voltage $U < 160 \text{ V}$ or Over voltage $U > 253 \text{ V}$ 2. Module overheating: temperature inside motor is too high	1. Check voltage supply $195 \text{ V} < U < 253 \text{ V}$ 2. Check water and ambient temperature
LED blinks red	Circulation pump out of function	Circulation pump stopped (blocked)	Circulation pump does not restart by itself due to a permanent failure	Change circulation pump
LED off	No power supply	No voltage on electronics	1. Circulation pump is not connected to power supply 2. LED is damaged 3. Electronics are damaged	1. Check cable connection 2. Check if circulation pump is running 3. Change circulation pump



www.esbe.eu



NO.1 IN HYDRONIC SYSTEM CONTROL

6 GRUNDFOS - CIRCULATION PUMP

USER INTERFACE

The user interface is designed with a single push button, one red/green LED and four yellow LEDs.

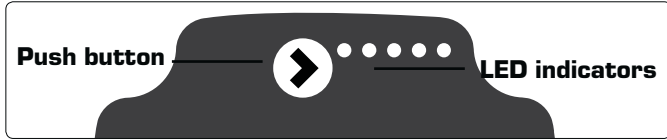

NAVIGATION - KEY LOCK FUNCTION

The purpose of the key lock function is to avoid accidental change of settings and misuse. When the key lock function is enabled, all long key presses will be ignored. This prevents the user from entering the "select setting mode" area and allows the user to see the "show setting mode" area.

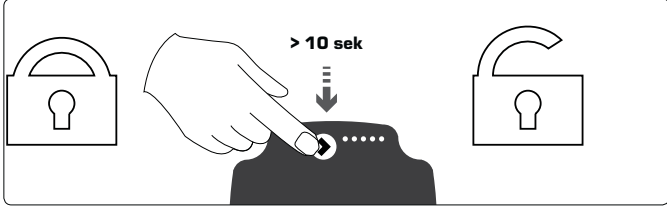

If you press the key lock for more than 10 seconds, you can toggle between enabling/disabling the key lock function. When doing so, all LEDs will flash for a second indicating that lock is toggled.

SETTING SELECTION

You can choose between the performance view and settings view. If you press the button for 2 to 10 seconds, the user interface switches to "setting selection" if the user interface is unlocked. You can change the settings as they appear. The settings appear in a particular order in a closed loop. When you release the button and wait for 10 seconds, the user interface switches back to the performance view and the last setting is stored.

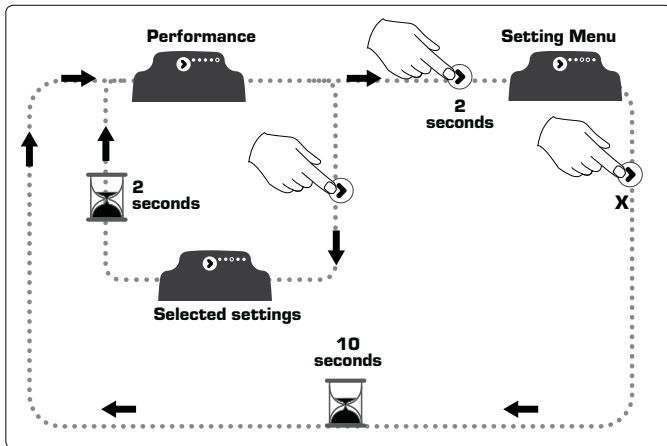

More information on page 6 - Operation Status, Alarm Status and Settings view

OPERATION MODE

This circulator gives the opportunity of external PWM signal control with profile A or C or internal control with three control modes plus AUTOADAPT.

Proportional pressure mode

UPM3 xx-50	UPM3 xx-70	LED1 Green	LED2 yellow	LED3 yellow	LED4 yellow	LED5 yellow
PP1	PP1	●	●			
PP2	PP2	●	●		●	
PP3*	PP3*	●	●		●	●
AUTOADAPT	AUTOADAPT	●	●			●

PP: proportional pressure curve 1, 2, or 3.

* The circulator is factory-set to start in this control mode.

Constant pressure mode

AUTOADAPT	UPM3 xx-70	LED1 Green	LED2 yellow	LED3 yellow	LED4 yellow	LED5 yellow
CP1	CP1	●		●		
CP2	CP2	●		●	●	
CP3	CP3	●		●	●	●
AUTOADAPT	AUTOADAPT	●		●		●

CP: constant pressure curve: 1, 2, or 3.

Constant curve mode

UPM3 xx-50 (m)	UPM3 xx-70 (m)	LED1 Green	LED2 yellow	LED3 yellow	LED4 yellow	LED5 yellow
2	4	●	●	●		
3	5	●	●	●	●	
4	6	●	●	●	●	●
5	7	●	●	●		●

PWM profile A (heating)

UPM3 xx-50 (m)	UPM3 xx-70 (m)	LED1 Red	LED2 yellow	LED3 yellow	LED4 yellow	LED5 yellow
2	4	●	●			
3	5	●	●		●	
4	6	●	●		●	●
5	7	●		●		●

PWM profile C (solar)

UPM3 xx-50 (m)	UPM3 xx-70 (m)	LED1 Red	LED2 yellow	LED3 yellow	LED4 yellow	LED5 yellow
2	4	●		●		
3	5	●		●	●	
4	6	●		●	●	●
5	7	●		●		●

OPERATION STATUS

In performance view, the first LED is always green as long as there are no alarms. In the settings view, it can be either green or red, indicating internal or external control. The four yellow LEDs indicate the current power consumption (**P1**) as shown in the figure and table below.

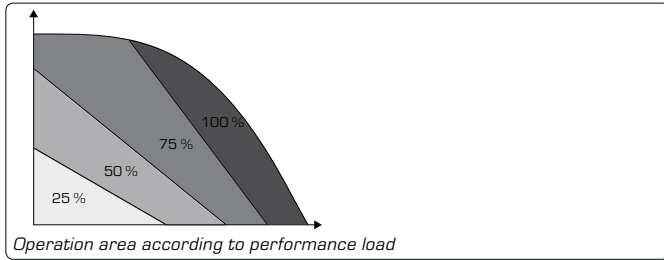

When the operation mode is active, all active LEDs are constantly on in order to differentiate this mode from the select setting mode. If the circulator is stopped by an external signal, LED 1 flashes green.

DISPLAY	INDICATION	PERFORMANCE IN % OF P1 MAX
One green LED (flashing)	Standby (only externally controlled)	0
One green LED + one yellow LED	Low	0-25
One green LED + two yellow LED	Medium low	25-50
One green LED + three yellow LED	Medium high	50-75
One green LED + four yellow LED	High	75-100

ALARM STATUS

If the circulator has detected one or more alarms, the bi-colored LED 1 switches from green to red. When an alarm is active, the LEDs indicate the alarm type as defined in the table below. If multiple alarms are active at the same time, the LEDs only show the error with the highest priority. The priority is defined by the sequence of the table. When there is no active alarm anymore, the user interface switches back to operation mode.

DISPLAY	INDICATION	PUMP OPERATION	COUNTER ACTION
One red LED + one yellow LED (LED 5)	Rotor is blocked	Trying to start again every 1.33 seconds.	Wait or deblock the shaft.
One red LED + one yellow LED (LED 4)	Supply voltage too low.	Only warning, pump runs.	Control the supply voltage.
One red LED + one yellow LED (LED 3)	Electrical error:	Pump is stopped because of low supply voltage or serious failure.	Control the supply voltage / Exchange the pump.

SETTINGS VIEW

You can switch from the performance view to the settings view by pressing the push button. The LEDs indicate the actual setting. The settings view shows which mode controls the circulator: No settings can be made at this stage. After 2 seconds, the display switches back to performance view. If LED 1 is green, it indicates operation or internal control. If LED 1 is red, it indicates alarm or external control. LED 2 and 3 indicate the different control modes and LED 4 and 5 indicate the different curves.

	LED 1	LED 2	LED 3	LED 4	LED 5
Proportional pressure	green	●			
Constant pressure	green		●		
Constant curve	green	●	●		
PWM A profile	red	●			
PWM B profile	red		●		
Curve 1					
Curve 2				●	
Curve 3				●	●
Curve 4 / AUTOADAPT					●

Note: ● = The LED is yellow.



HOW TO USE THE INFORMATION LEAFLET

The Return Temperature Unit is equipped with an information display containing a leaflet that graphically explains what kind of application the unit is controlling. It gives you also the possibility to write in notes and leave your business card behind. Just remove the display glass and select the suitable information.

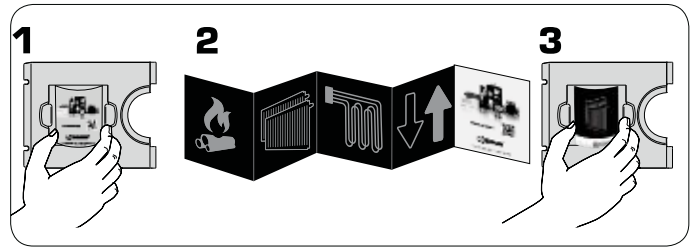

MAINTENANCE

The Return Temperature Unit does not require any specific maintenance under normal conditions. Although it is important to annually check the entire system. Pay special attention to all threaded or soldered connections and the potential occurrence of limestone sedimentation.

⚠ WARNING Switch of the electric supply before any operation. Pay attention to the hot water contained.



SPARE PARTS

Spare parts are ordered via ESBE customer service. In order to avoid queries and incorrect orders, all data on the name plate should be submitted for each order.

